



**2010 Collegiate  
Design Series**

**Aero Design<sup>®</sup>  
East and West  
Rules**

Rev 9.11.2009

---

<b>FOREWORD .....</b>	<b>3</b>
<b>SECTION 1.0 REQUIREMENTS FOR ALL CLASSES.....</b>	<b>4</b>
1.1 INTRODUCTION.....	4
1.2 MULTIPLE ENTRIES .....	6
1.3 REGISTRATION INFORMATION AND DEADLINES .....	6
1.4 COMPLAINTS, PROTESTS AND QUESTIONS.....	10
1.5 PROFESSIONAL CONDUCT.....	11
<b>SECTION 2.0 MISSION REQUIREMENTS.....</b>	<b>13</b>
2.1 TAKEOFF .....	13
2.2 COMPETITION CIRCUIT REQUIREMENTS .....	13
2.3 LANDING .....	14
<b>SECTION 3.0 REGULAR CLASS REQUIREMENTS .....</b>	<b>17</b>
3.1 AIRCRAFT REQUIREMENTS AND RESTRICTIONS .....	17
3.2 AIRCRAFT SYSTEM REQUIREMENTS .....	18
3.3 GENERAL REQUIREMENTS.....	20
3.4 REGULAR CLASS SCORING .....	20
<b>SECTION 4.0 ADVANCED CLASS REQUIREMENTS .....</b>	<b>22</b>
4.1 AIRCRAFT REQUIREMENTS AND RESTRICTIONS .....	22
4.2 AIRCRAFT SYSTEMS REQUIREMENTS .....	23
4.3 GENERAL REQUIREMENTS.....	25
4.4 ADVANCED CLASS SCORING .....	25
<b>SECTION 5.0 MICRO CLASS REQUIREMENTS .....</b>	<b>28</b>
5.1 AIRCRAFT REQUIREMENTS AND RESTRICTIONS .....	28
5.2 AIRCRAFT SYSTEMS REQUIREMENTS .....	29
5.3 GENERAL REQUIREMENTS.....	31
5.4 MICRO CLASS SCORING .....	32
<b>SECTION 6.0 DESIGN REPORTS AND TECHNICAL PRESENTATION.....</b>	<b>34</b>
6.1 DESIGN REPORTS .....	34
6.2 TECHNICAL PRESENTATIONS.....	38
6.3 TECHNICAL INSPECTION.....	39
6.4 TOTAL COMPETITION SCORING .....	40
6.5 PROJECTION EQUIPMENT.....	40
6.6 TIE BREAKERS.....	40
<b>SECTION 7.0 FUTURE RULE CHANGES.....</b>	<b>41</b>
<b>STATEMENT OF COMPLIANCE .....</b>	<b>42</b>

---

## Foreword

If you are reading this, it means you have accepted, or at the very least, contemplating on accepting, the Aero Design 2010 challenge. Either way, we (the SAE Rules Committee) would like to inform competitors on this year's challenges and thoughts behind our decisions...as well as future directions.

Regular Class continues to be the class with the purpose to develop the fundamental understanding of flight. Last year, teams were prohibited from using carbon fiber and fiberglass. This limitation continues this year in addition to prohibiting the use of fiber-reinforced plastics. Why the restrictions on these materials? We have received numerous feedback from the engineers who read your technical papers and the consensus is that teams are "over-building" their airframes. It is easy to come up with an overly strong carbon fiber/fiberglass fuselage that can carry a heavy load. It is much harder to design the same fuselage using "minimum" materials and still achieve the weight carrying goal. This requires the use of stress analysis...which is what our volunteer engineering judges want to see...a team that did their homework. Speaking of basics, there is another addition for the design reports; stability and control requirements have been added. I am sure that this will generate a lot of questions and comments, so please follow the forum carefully and regularly for updates. These are just two items that have changed so please read the rules carefully for all changes to this class.

For the most part, Micro Class continues in the same direction as last year with one exception. We have introduced a "standard" carrying case...smaller from last year, of course. We have seen excellent progress in this class! Students have had the opportunity to refine their designs and achieve a higher success rate from the previous two years. We hope this year will continue. Fair warning...expect big changes in this class next year. I cannot give you a preview as details are still being hammered out.

Now for the big announcement. Open Class is no more. In its place is a new Advance Class. Why call it Advance Class? Simple...the requirements for this new class will require teams to have a systems approach to the design while integrating several engineering disciplines: aeronautical, mechanical, electrical, and computer engineers. The ultimate end goal for this new class is autonomous flight with a "purpose". What purpose? Other aero competitions are also striving for autonomous flight...but that's it. We (the rules committee) believe this is not enough. Aircraft are built for a purpose or mission. Autonomous flight without a mission is senseless. This year will be a "baby step" toward purpose-driven autonomous flight. For the time being, that purpose is still a heavy-lift, but that will definitely change in the coming years. I use the term "baby step" for a reason. The systems developed for this year's aircraft will have direct application for each subsequent year. In other words, teams will build on previous years design and never have to start over...unless you want to that is. Since this is the first year for Advance Class, it opens up the possibility of "unforeseen" changes that will have to be made as we go along. I ask that students be patient and help us with constructive advice in achieving this goal. Again, please follow the forum carefully and frequently for any updates.

Good luck to all and see you soon at the competitions.

Oliver Alvarado  
SAE Rules Committee Chair  
Lockheed Martin Aeronautics Co.

---

## SECTION 1.0 Requirements for all Classes

### 1.1 Introduction

#### 1.1.1 Official Announcements and Competition Information

The Aero Design competition is intended to provide undergraduate and graduate engineering students with a real-life engineering exercise. The competition has been designed to provide exposure to the kinds of situations that engineers face in the real work environment. First and foremost a design competition, students will find themselves performing trade studies and making compromises to arrive at a design solution that will optimally meet the mission requirements while still conforming to the configuration limitations.

The importance of interpersonal communication skills is often overlooked by engineers, yet both written and oral communication skills are vital in the engineering workplace. To help teams develop these skills, a high percentage of a team's score is devoted to the Design Report and the oral presentation required in the competition.

Aero Design features three classes of competition—**Regular**, **Advanced**, and **Micro**. Regular Class is intended to be simpler than Advanced Class, and therefore more accessible to the fledgling team. Advanced Class is intended to be less restrictive than Regular Class, thereby opening a larger potential solution set. Its lack of restriction allows teams to pursue more complex vehicle configurations, thereby encouraging greater creativity in satisfying the mission requirements. Micro Class teams are required to make trades between two potentially conflicting requirements, carrying the highest payload fraction possible, while simultaneously pursuing the lowest empty weight possible.

Other SAE Aero Design Competitions: Aero Design Brazil; SAE BRASIL - <http://www.saebrasil.org.br/>

#### 1.1.2 Team Member Eligibility

Teams are required to read the articles posted on the SAE Aero Design homepage (<http://students.sae.org/competitions/aerodesign/>) published by SAE and the other organizing bodies. Teams must also be familiar with all official announcements concerning the competitions and rule interpretations released by the Aero Design Rules Committee.

#### 1.1.3 Society membership

Individual team members must be members of at least one of the following societies: (1) SAE or an SAE affiliate society, (2) ATA, or (3) IMechE. Proof of membership, such as a membership card, is required at the event.

---

Students who are members of one of the societies listed above are not required to join any of the other societies in order to participate in any SAE competition.

**COMMENT:** Students may join online at [www.sae.org/students](http://www.sae.org/students).

#### **1.1.4 Pilots**

Pilots are not required to be students or SAE members, but they must be current members of either the **Academy of Model Aeronautics** or the **national model aircraft club** in their country of origin (such as the MAAC for Canadian teams). Valid AMA membership cards must be presented at the flying field prior to flying any team's aircraft. Copies of AMA application forms will not suffice as proof of AMA membership; the actual AMA card must be presented at the event flying field.

#### **1.1.5 Liability Waiver and Insurance Requirements**

All on-site participants and faculty advisors are required to sign a liability waiver upon registration. Individual medical and accident insurance coverage is the sole responsibility of the participant.

#### **1.1.6 Ringers Prohibited**

In order to maintain the integrity of a fair competition, the faculty advisor must prohibit ringers. A ringer is someone that has exceptional skills related to the competition (e.g., a professional model builder) who cannot be a legal member of the team but helps the team win points.

#### **1.1.7 Design and Fabrication**

The airplane must be designed and built by the SAE student members without direct involvement from professional engineers, radio control model experts, pilots, machinists, or related professionals. The students may use any literature or knowledge related to R/C aircraft design and construction and information from professionals or from professors as long as the information is given as discussion of alternatives with their pros and cons and is acknowledged in the references in the design report. Professionals may not make design decisions, nor contribute to the drawings, the report, or the construction of the airplane. The faculty advisor must sign the Statement of Compliance given in Appendix.

#### **1.1.8 Original Design**

Any aircraft presented for competition must be an original design whose configuration is conceived by the student team members. Photographic scaling of an existing model aircraft design is not allowed. Use of major components such as wings, fuselage, or empennage of existing model aircraft kits is prohibited. Use of standard model aircraft hardware such as engine mounts, control horns, and landing gear is allowed.

#### **1.1.9 Official Languages**

The official language of the SAE Aero Design series is English.

---

Document submissions, presentations and discussions in English are acceptable at all competitions in the series.

Team members, judges and officials at Non U.S. competition events may use their respective national languages for document submissions, presentations and discussions if all the parties involved agree to the use of that language.

Aero Design East	English
Aero Design West	English
Aero Design Brazil	Portuguese and English

## 1.2 Multiple Entries

### 1.2.1 Unique Designs

Universities may enter more than one team in each Aero Design competition, but each entry must be a unique design, significantly different from each other. If the aircraft are not significantly different in the opinion of the Organizer, then the university will be considered to have only a single entry and only one of the teams and its aircraft will be allowed to participate in the competition. For example, two aircraft with identical wings and fuselages but different empennage would likely not be considered significantly different. For guidance regarding this topic, please email [CollegiateCompetitions@sae.org](mailto:CollegiateCompetitions@sae.org).

### 1.2.2 Aircraft Classification/Duplicate Aircraft

Aircraft may only compete in one class. Simultaneous entry in Open(Advanced), Regular, and Micro Class, with the same aircraft, is not allowed. When a team has an identical aircraft as a back-up, the back-up aircraft must go through inspection with the primary aircraft. If the entire back-up aircraft is used in competition, previously earned flight points are forfeited and flight point scoring starts over.

### 1.2.3 Aircraft Eligibility

Aircraft will only be allowed to compete during a single academic year. Aircraft may be entered in both Aero Design East and Aero Design West during the same calendar year, but that same aircraft may not be used in either competition during the following year. Entering the same aircraft in Aero Design West one year and Aero Design East the next year is not allowed.

## 1.3 Registration Information and Deadlines

Teams intending to participate in the 2010 SAE Aero Design competitions must register their teams online starting **Monday, October 5, 2009 at 10:00 AM EDT** by the following deadlines:

---

Aero Design East – Lockheed Martin Aeronautics Company, Fort Worth, TX;  
**Monday, December 21, 2009 at 11:59 PM Eastern Standard Time.**

Aero Design West – Lockheed Martin Aeronautics Company, Van Nuys, CA;  
**Monday, December 21, 2009 at 11:59 PM Eastern Standard Time.**

The registration fee is non-refundable and failure to meet these deadlines will be considered a failure to qualify for the competition. Separate entry fees are required for the East and West events.

The registration fees indicated in the Appendix (\$ 600) must be paid online by credit card at the time of online registration. Registration fees may not be paid by any other means.

Please note each Aero Design event will be limited to 65 teams.

### **1.3.1 Individual Registration Requirements – ACTION REQUIRED**

All participating team members and faculty advisors must be sure that they are individually linked to their respective school / university on the SAE website.

If you are not an SAE member, go to [www.sae.org](http://www.sae.org) and select the “Join SAE / Membership Renewal” link under “Quicklinks”, and then select the “Join SAE” link in the top right column. Students will need to select the “Student Membership” link and then follow the series of questions that are asked. Faculty members who wish to become SAE members should choose the “Professional Membership” link. Please note all student participants must be SAE members to participate in the events; this is not mandatory for faculty advisors.

All international student participants, or unaffiliated faculty advisors, who are not SAE members are required to complete the International Student Registration form per team found on the Registration page of the specific event

(<http://students.sae.org/competitions/aerodesign/west/registration.htm>).

Upon completion, email the form to [CollegiateCompetitions@sae.org](mailto:CollegiateCompetitions@sae.org).

All student participants and faculty advisors must affiliate themselves to the appropriate team(s) online. To do this you will need to go to the Aero Design homepage and select the SAE Aero Design Series link to expand the menu. Select the event(s) that you are registered for, and once the menu expands, click on the Registration link. From here you will select the “Register Your Team / Update Team Information” link in which your team links should appear on the next page. Select the team link and scroll to the bottom of the page; the “Add New Member” button will allow individuals to include themselves with the rest of the team.

---

Once you've associated yourself to your respective university team(s), all affiliated students and faculty must complete the following information on the SAE website:

- 1.) Medical insurance (provider, policy/ID number, telephone number)
- 2.) Driver's license (state/country, ID number)
- 3.) Emergency contact data (point of contact (parent/guardian, spouse), relationship, phone number)

The "Add New Member" button will allow individuals to access this page and include the necessary credentials. If the individual is already affiliated to the team, simply select the Edit button next to the name. Please be sure this is done separately for each of the events your team has entered.

PLEASE BRING YOUR OFFICIAL DRIVER'S LICENSE OR PHOTO I.D./PASSPORT AS WELL AS YOUR MEDICAL INSURANCE CARD TO ONSITE REGISTRATION.

All students, both domestic and international, must affiliate themselves online or submit the International Student Registration form by February 26, 2010. For additional assistance, please contact [CollegiateCompetitions@sae.org](mailto:CollegiateCompetitions@sae.org).

**\*\*NOTE: When your team is registering for a competition, only the student or faculty advisor completing the registration needs to be linked to the school. All other students and faculty can affiliate themselves after registration has been completed, however this must be done on or before February 26, 2010.**

### 1.3.2 Faculty Advisor

Each team is expected to have a Faculty Advisor appointed by the university. The Faculty Advisor is expected to accompany the team to the competition and will be considered by competition officials to be the official university representative.

Faculty Advisors may advise their teams on general engineering and engineering project management theory, but may not design any part of the vehicle nor directly participate in the development of any documentation or presentation. Additionally Faculty Advisors may neither fabricate nor assemble any components nor assist in the preparation, maintenance, or testing of the vehicle.

In Brief - Faculty Advisors may not design, build or repair any part of the plane.

### 1.3.3 SAE Aero Design Rules and Organizer Authority

### Rules Authority

The SAE Aero Design Rules are the responsibility of the SAE Aero Design Rules Committee and are issued under the authority of the SAE University Programs Committee. Official announcements from the SAE Aero Design Rules Committee, SAE or the other SAE Aero Design organizers shall be considered part of, and shall have the same validity as these rules.

Ambiguities or questions concerning the meaning or intent of these rules will be resolved by the SAE Aero Design Rules Committee, SAE staff or by the individual competition organizers as appropriate.

### Rules Validity

The SAE Aero Design Rules posted on the SAE website and dated for the calendar year of the competition are the rules in effect for the competition. Rule sets dated for other years are invalid.

### Rules Compliance

By entering an SAE Aero Design competition the team members of the team as individuals, faculty advisors and other personnel of the entering university agree to comply with, and be bound by, these rules and all rule interpretations or procedures issued or announced by SAE, the SAE Aero Design Rules Committee and the other organizing bodies. All team members, faculty advisors and other university representatives are required to cooperate with, and follow all instructions from, competition organizers, officials and judges.

### Understanding the Rules

Teams are responsible for reading and understanding the rules in effect for the competition in which they are participating. The section and paragraph headings in these rules are provided only to facilitate reading; they do not affect the paragraph contents.

### Participating in the Competition

Teams, team members as individuals, faculty advisors and other representatives of a registered university who are present on-site at a competition are considered to be “participating in the competition” from the time they arrive at the event site until they depart the site at the conclusion of the competition or earlier by withdrawing.

### Violations of Intent

The violation of the intent of a rule will be considered a violation of the rule itself. Questions about the intent or meaning of a rule may be addressed to the SAE Aero Design Rules Committee or by the individual competition organizers as appropriate.

### Right to Impound

---

SAE and the other competition organizing bodies reserve the right to impound any on-site registered aircraft at any time during a competition for inspection and examination by the organizers, officials and technical inspectors.

#### General Authority

SAE and the competition organizing bodies reserve the right to revise the schedule of any competition and/or interpret or modify the competition rules at any time and in any manner that is, in their sole judgment, required for the efficient operation of the event or the Aero Design series as a whole.

**NOTICE:** In the event that the number of teams registering for the competition exceeds the number of teams/participants the facilities can handle, then registration priority will be given to colleges and universities with SAE student chapters.

## **1.4 Complaints, Protests and Questions**

### **1.4.1 Complaints**

Competition officials will be available to listen to complaints regarding errors in scoring, interpretation, or application of the rules during the competition. Competition officials will not be available to listen to complaints regarding the nature, validity, or efficacy of the rules themselves at the competition. In other words, the Organizer will not change the rulebook at the field.

### **1.4.2 Protests / Preliminary Review**

If a team has a question about scoring, judging, policies, or any official action, they must bring the question to the Organizer's or SAE staff's attention for an informal preliminary review before a protest is filed.

### **1.4.3 Cause for Protest**

A team may protest any rule interpretation, score or official action (unless specifically excluded from protest) which they feel has caused some actual, non-trivial, harm to their team, or has had a substantive effect on their score. Teams may not protest rule interpretations or actions that have not caused them any substantive damage.

### **1.4.4 Protest Format**

If a faculty advisor or team captain feels that his complaint about an official action or rules interpretation was not properly addressed by the event officials, he or she may protest. All protests must be filed in writing to the Organizer by the faculty advisor or team captain only.

---

#### **1.4.5 Protest Period**

All protests must be submitted within thirty (30) minutes of the end of the flight round or other competition event to which the protest relates.

#### **1.4.6 Protest Committee**

Any protests must be reviewed by the Protest Committee. The Protest Committee must consist of a minimum of three members: the Organizer, an SAE Collegiate Design Series representative, and either the Chief Steward, the Chief Judge, or the Air Boss. The decision of the Protest Committee must be final. If a member of the Aero Design Rules Committee is at the competition, he or she will be in the Protest Committee.

#### **1.4.7 Protest Resolution**

In order to have a protest considered, a team will be required to post twenty five (25) points as collateral. If the protest is sustained, the appropriate correction will be applied and the team will forfeit no points. If the protest is overruled, the team will forfeit the twenty five (25) collateral points.

#### **1.4.8 Questions**

Any questions or comments about the rules should be brought to the attention of the Rules Committee via the SAE Aero Design forum at [http://forums.sae.org/access/dispatch.cgi/aerodesign\\_pf](http://forums.sae.org/access/dispatch.cgi/aerodesign_pf)

General information about hotels and other attractions in the area as well as a schedule of events will be posted on the SAE website according to the competition in which you are competing:

<http://students.sae.org/competitions/aerodesign/>

### **1.5 Professional Conduct**

#### **1.5.1 Unsportsmanlike Conduct**

In the event of unsportsmanlike conduct by team members or that team's faculty advisor, the team will receive a warning from a Competition Official. A second violation will result in expulsion of the team from the competition and loss of any points earned in all aspects of the competition.

#### **1.5.2 Arguments with Officials**

Arguments with or disobedience toward any competition official may result in the team being eliminated from the competition. All members of the team may be immediately escorted from the grounds.

#### **1.5.3 Alcohol and Illegal Material**

Alcoholic beverages, illegal drugs, firearms, weapons, or illegal material of any type are not permitted on the event sites at any time during the competition. Any violations of this rule will result in the immediate

expulsion of all members of the offending school, not just the individual team member in violation. This rule applies to team members and faculty advisors. Any use of illegal drugs or any use of alcohol by an underage person must be reported to the local law enforcement authorities for prosecution.

#### **1.5.4 Organizer's Authority**

The Organizer reserves the exclusive right to revise the schedule of the competition and/or to interpret the competition rules at any time and in any manner which is required for efficient operation or safety of the competition.

---

## SECTION 2.0 Mission Requirements

### 2.1 Takeoff

Takeoff is defined as the point at which the main wheels leave the ground.

#### 2.1.1 Time Limit

Upon a signal given by the Air Boss, each team will have three (3) minutes to accomplish a successful takeoff. Multiple takeoff attempts are allowed within the three-minute window as long as the aircraft has **NOT** become airborne during an aborted attempt.

#### 2.1.2 Takeoff Zone

Regular Class aircraft must lift from the ground within a takeoff zone measuring 200 feet (61m) in length.

Micro Class aircraft must lift from the ground within a takeoff zone measuring 100 feet (30m) in length. Takeoff direction will be determined by the Air Boss, and selected to face into the wind. Aircraft must remain on the runway during the takeoff roll.

Advanced Class shall have the full use of the runway. There is no takeoff limit.

#### 2.1.3 Engine Run-up

Use of a helper to hold the model while the engine is revved prior to release for takeoff is allowed, but the helper may not push the model upon release. To stay within the takeoff zone, the main wheels of the aircraft are to be placed on the takeoff line.

#### 2.1.4 Aircraft Configuration upon Liftoff

The aircraft must remain intact during takeoff, from release through liftoff. No parts may depart the aircraft during the takeoff process.

### 2.2 Competition Circuit Requirements

The aircraft must successfully complete one 360° circuit of the field. During departure and approach to landing, the pilot must not fly the aircraft in a pattern that will allow the aircraft to enter any of the no-fly zones (See Para. 20.3.4). More than one circuit of the field is allowed. During a flight, each aircraft must fly past the departure end of the takeoff zone, turn the aircraft through approximately 180° of heading, and fly past the approach end of the takeoff zone prior to landing. No aerobatic maneuvers will be allowed at any time during the flight competition. This includes but not limited to: loops, figure 8's, immelmans, barrel rolls, etc.



Allowed

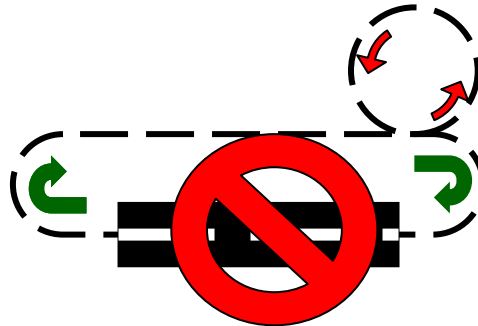

Not Allowed

## 2.3 Landing

Landing is defined as occurring from initial touchdown to the point at which the aircraft stops moving. Initial touchdown is defined as the point at which any part of the aircraft touches the ground.

### 2.3.1 Landing Zone

Regular Class aircraft must land in the same direction as takeoff within a designated landing zone measuring 400 feet (122m) in length.

Micro Class aircraft must land in the same direction as takeoff within a designated landing zone measuring 200 feet (61m) in length.

Advanced Class aircraft must land on the runway with the full use of the entire runway. Advance Class aircraft must land in the same direction as takeoff.

Touch-and-goes are not allowed, and a crash-landing invalidates the landing attempt. A good landing is defined as touching down within the designated landing zone for the class, and remaining on the ground through rollout. Rolling-out beyond the landing zone is allowed, provided the aircraft touches down within the landing zone. Bouncing across the boundary at the end of the landing zone is not allowed, and will be judged as a failed landing attempt. A failed landing attempt will result in no score for the round.

During a landing, the aircraft must remain on the runway between their landing limits to be considered a successful landing. Running off the side of the runway onto the grass is not allowed. If an aircraft crosses their respective landing limits, running off onto the grass is permitted.

### 2.3.2 Post-landing Condition

The aircraft must take off and land intact to receive points for the flight. All parts must remain attached to the aircraft during flight and landing

maneuver, with the exception of the propeller. Broken propellers are allowed, and will not invalidate a flight attempt.

### **2.3.3 Flight Authority**

The Organizer, Chief Judge, Air Boss, SAE Official, or other designated competition technical inspector may prohibit flight of any aircraft deemed non-flight-worthy until the non-flight-worthy condition has been repaired and the aircraft has been re-inspected by the judges.

### **2.3.4 Controllability**

All aircraft must be controllable in flight.

### **2.3.5 No-Fly Zone**

Each flying site will have site-specific no-fly zones. At no time is any aircraft to enter the no-fly zones, whether under controlled flight or uncontrolled. First infraction for crossing into the no-fly zone will result in an invalidated flight attempt and no points will be awarded for that flight. Second infraction will result in disqualification from the entire event and loss of all points. Flying over the pit area is not allowed at any time.

### **2.3.6 Flight Rules Announcement**

Flight will be explained to all teams before the flight competition begins, either during the pilots' meeting or during activities surrounding the technical inspections and oral presentations.

### **2.3.7 Flight Rules Violations**

Violation of any flight rule may result in the team being eliminated from the competition. All members of the team may be escorted from the grounds.

### **2.3.8 Local Field Rules**

In addition to competition rules, the local flying club may have additional rules in place at the event flying field. Club rules will be obeyed during the flight competition; for example, the club may have specific frequency control procedures that must be used during the event.

### **2.3.9 Repairs and Alterations**

The original design of the aircraft as presented in the written and oral reports must be maintained as the baseline aircraft during the course of the competition.

### **2.3.10 Repairs**

In the event of damage to the aircraft, the aircraft may be repaired provided such repairs do not drastically deviate from the original baseline design.

### **2.3.11 Alteration After First Flight**

Minor alterations are allowed after the first and subsequent flight attempts. Penalty will ONLY be assessed if 2/3 of the ruling committee (Event Director, Head Judge, SAE Judge) agree that there was significant modifications made from the baseline configuration. Changes due to safety will not be assessed with penalty points. Alteration must reported as described in section 6.3.4.

### **2.3.12 Ground Safety**

NO OPEN TOE SHOES ALLOWED. All team participants, including faculty advisors and pilots, will be required to wear CLOSED toe shoes during flight testing and during flight competition.

### **2.3.13 Flight Line Safety**

**All students involved at the flight line shall wear safety glasses.**

---

## SECTION 3.0 Regular Class Requirements

### Design Objective:

The objective of Regular Class is to design an aircraft that can lift as much weight as possible while observing the available power and aircraft's length, width, and height requirements. Accurately predicting the lifting capacity of the aircraft is an important part of the exercise, as prediction bonus points often determine the difference in placement between competing teams.

### 3.1 Aircraft Requirements and Restrictions

#### 3.1.1 No lighter-than-air or rotary wing aircraft

Competing designs are limited to fixed wing aircraft only. No lighter-than-air or rotary wing aircraft such as helicopters or autogyros will be allowed to compete.

#### 3.1.2 Aircraft Dimension Requirement

**Fully configured for takeoff, the free standing aircraft shall have a maximum combined length, width, and height of 200 inches. Aircraft exceeding this design requirement will be disqualified from the competition.**

Length is defined as the maximum distance from front to the aft of the aircraft. Width is the span or the maximum distance from wingtip to wingtip. Height is defined as the maximum distance perpendicular to the ground to the highest part of the aircraft (propeller not included).

#### 3.1.3 Gross Weight Limit

Regular Class aircraft may not weigh more than fifty five (55) pounds with payload and fuel.

#### 3.1.4 Payload Bay Limit(s)

Regular Class aircraft must be capable of carrying a minimum fully enclosed rectangular block measuring 5 inches by 5 inches by 10 inches (5" x 5" x 10"). During technical inspection, compliance with this rule must be tested by inserting a block with these dimensions into the aircraft. This block must be easily inserted and removed without application of excessive force during insertion or extraction, and the aircraft must be structurally airworthy with the block installed. Aircraft not capable of carrying a fully enclosed cargo block will be disqualified from the competition.

#### 3.1.5 Aircraft Identification

Team number as assigned by SAE must be visible on both the top and bottom of the wing, and on both sides of the vertical stabilizer or other vertical surface in 4-inch numbers. The University name must be clearly

---

displayed on the wings or fuselage. The University initials may be substituted in lieu of the University name provided the initials are unique and recognizable.

The assigned aircraft numbers appear next to the school name on the “Registered Teams” page of the SAE Aero Design section of the Collegiate Design Series website at:

**Aero East:**

<http://www.sae.org/students/aeroeast.htm>

**Aero West:**

<http://www.sae.org/students/aerowest.htm>

### **3.1.6 Name and Address**

Regular Class aircraft must be identified with the school name and address either on the outside or the inside of the aircraft.

### **3.1.7 Material Restriction**

The use of Fiber-Reinforced Plastic (FRP) is prohibited on all parts of the aircraft. The only exception is the use of a commercially available engine mount and propeller. Exploration of other materials and building methods are greatly encouraged.

## **3.2 Aircraft System Requirements**

### **3.2.1 Engine Requirements**

Regular Class aircraft must be powered by a single, unmodified O.S. .61FX with E-4010 Muffler. No muffler extensions or headers that fit between the engine cylinder and the muffler may be used. Muffler baffles must be installed, and must be unmodified from the factory installed configuration. No fuel pumps are allowed.

While the engine may not be modified from its stock configuration, two specific components may be installed on the engine for convenience and/or safety purposes:

(a) Remote needle valves, including needle valves that may be adjusted in flight, are allowed.

**(b) Tubes that redirect the exhaust flow may be affixed to the exhaust pipe.**

<p><b>NOTE:</b> Engine tear-down and inspection may be performed by the competition officials at any time during the competition.</p>
---

### **3.2.2 Gear boxes, Drives, and Shafts**

Gearboxes, belt drive systems, and propeller shaft extensions are allowed

as long as a one-to-one propeller to engine RPM is maintained. The prop(s) must rotate at engine RPM.

### **3.2.3 Competition Supplied Fuel**

The fuel for Regular Class entries will be a common grade, ten percent (10%) nitro methane fuel supplied by the Organizer.

### **3.2.4 Fuel Tanks**

Fuel tanks must be accessible to determine contents during inspections. Tanks may be pressurized by a stock fitting on the engine muffler only.

### **3.2.5 Gyroscopic Assist Prohibited**

No gyroscopic assist of any kind is allowed in the Regular Class.

### **3.2.6 Payload Requirements**

#### **3.2.6.1 Payload and Payload Support**

The payload must consist of a support assembly and payload plates. All payload carried for score must be carried within the cargo bay. The support assembly must be constructed so as to retain the weights as a homogeneous mass. There is no required configuration for the payload plates. An example of one possible payload support configuration is provided below, but this is only an example. The design of the support assembly will depend upon the configuration of the payload plates. The payload must be secured to the airframe to ensure the payload will not shift or come loose in flight. The total payload consists of the plates plus the support assembly. It is the responsibility of each team to provide its own payload plates.

#### **Example Payload Assembly Section**

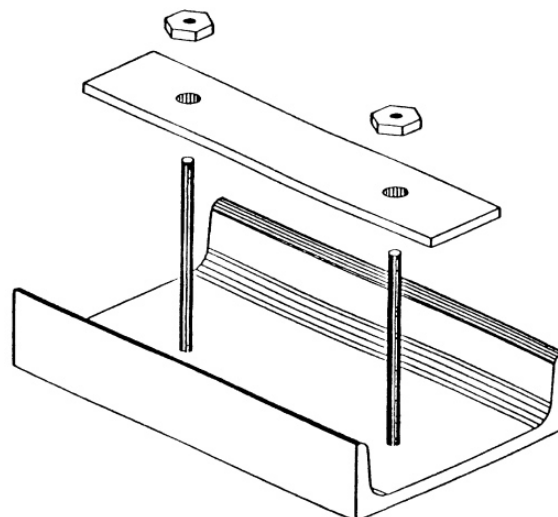

### **3.2.6.2 Payload Distribution**

The payload cannot contribute to the structural integrity of the airframe, and must be secured to the airframe within the cargo bay so as to avoid shifting while in flight.

## **3.3 General Requirements**

### **3.3.1 Radios (New requirement)**

The use of 2.4 GHz radio is required for all aircraft competing in the 2010 competition.

### **3.3.2 In-Flight Battery Packs**

Regular Class aircraft must use a battery pack with no less than five hundred (500) mAh capacity. Batteries may be charged at any time on the ground.

### **3.3.3 Spinners or Safety Nuts Required**

All aircraft must utilize either a spinner or a rounded safety nut.

### **3.3.4 Metal Propellers Prohibited**

Metal propellers are not allowed.

### **3.3.5 Control Surface Slop**

Aircraft control surfaces must not feature excessive slop. Sloppy control surfaces lead to reduced controllability in mild cases, or control surface flutter in severe cases.

### **3.3.6 Servo Sizing**

Analysis and/or testing must be described in the Design Report that demonstrates the servos are adequately sized to handle the expected aerodynamic loads during flight.

### **3.3.7 Qualification Flights**

Qualification flights are not required.

## **3.4 Regular Class Scoring**

An Empty Payload Bonus will be available for Regular Class. See section 3.4.4 for details.

In order to participate in the flight portion of the competition, each team is required to have submitted AND received a score for their Design Report and Oral Presentation.

### **3.4.1 Regular Class Flight Score**

Regular Class aircraft will receive a flight score based upon the raw

---

weight lifted and the team's prediction of the aircraft's maximum lifting capacity.

$$FS = RAW + PPB + EWB - TP$$

<i>RAW</i>	= Raw Weight Score
<i>PPB</i>	= Prediction Point Bonus
<i>EWB</i>	= Empty Weight Bonus
<i>TP</i>	= Total Penalty Points

### 3.4.2 Raw Weight Score

The raw weight score will be determined by multiplying the weight lifted in pounds by 4. Lifting 25 pounds will result in a raw weight score of 100 points.

$$RAW = W \times 4$$

*W* = Weight Lifted in Pounds

### 3.4.3 Payload Prediction Bonus

The prediction bonus will be determined according to the following formula:

$$PPB = 20 - (P_{\text{Predicted}} - P_{\text{Actual}})^2$$

<i>P<sub>Predicted</sub></i>	= Predicted Payload
<i>P<sub>Actual</sub></i>	= Actual Payload

If the above number is positive, the resulting number will be applied as the prediction bonus. If the above number is negative, no bonus will be applied.

### 3.4.4 Empty Payload Bonus

A 10 point Empty Weight Bonus (EWB) will be awarded if a successful flight with zero (0) payload achieved. EWB can only be obtained in the first flight round of competition.

### 3.4.5 Total Penalty Points

Any penalties assessed during Design Report Submission, Technical Inspection, and Aircraft Modifications will be applied to the overall Flight Score.

---

## SECTION 4.0 Advanced Class Requirements

### Design Objectives:

The objective of the Advanced Class is to design an aircraft with an on-board Data Acquisition System (DAS) while carrying as much weight as possible. Adding a DAS will provide students insight into two areas of interest in today's industry; autonomous flight and flight test data collection.

### 4.1 Aircraft Requirements and Restrictions

#### 4.1.1 No Lighter-Than-Air or Rotary Wing Aircraft

Competing designs are limited to fixed wing aircraft only. No lighter-than-air or rotary wing aircraft such as helicopters or autogyros will be allowed to compete.

#### 4.1.2 Gross Weight Limit

Advanced Class aircraft may not weigh more than fifty five (55) pounds with payload and fuel.

#### 4.1.3 Wing Span Limit

Advanced Class aircraft are not limited by wing span.

#### 4.1.4 Payload Bay Limit(s)

Advanced Class aircraft have no restrictions as to size, shape, or number of payload bays.

#### 4.1.5 Aircraft Identification

Team number as assigned by SAE must be visible on both the top and bottom of the wing, and on both sides of the vertical stabilizer or other vertical surface in 4-inch numbers. The University name must be clearly displayed on the wings or

fuselage. The University initials may be substituted in lieu of the University name provided the initials are unique and recognizable.

The assigned aircraft numbers appear next to the school name on the "Registered Teams" page of the SAE Aero Design section of the Collegiate Design Series website at:

#### Aero East:

<http://www.sae.org/students/aeroeast.htm>

#### Aero West:

<http://www.sae.org/students/aerowest.htm>

#### 4.1.6 Name and Address

Advanced Class aircraft must be identified with the school name and

---

address either on the outside or the inside of the aircraft.

## **4.2 Aircraft Systems Requirements**

### **4.2.1 Engine Requirements**

Advanced Class aircraft must be solely powered by internal combustion, reciprocating engines. The total displacement of Advanced Class engines may not exceed .65 cubic inches. The common-use displacement will be used to determine displacement, i.e. the advertised displacement.

Advanced Class aircraft are not limited to the number of engines. No changes to the internal displacement of the engine(s) will be allowed. There is, however, no restriction to the make and model of the engine(s).

### **4.2.2 Stored Energy Restriction**

Advanced Class aircraft must be powered by the engine(s) on board the aircraft. No other internal and/or external forms of stored potential energy allowed.

### **4.2.3 Propeller and Gearbox Issues**

Gearboxes are allowed in Advanced Class in which the propeller RPM differs from the engine RPM. Multiple engines, multiple propellers, propeller shrouds, and ducted fans are allowed in Advanced Class.

### **4.2.4 Competition Supplied Fuel**

Advanced Class teams may provide their own fuel, but fuel for Advanced Class entries must be acceptable for use by the AMA and the competition organizer. No fuel systems with gaseous boosts in which gases other than air enter the internal combustion engine will be allowed; pressurized air is also not allowed. Engines utilizing extremely hazardous fuels such as those containing tetranitromethane or hydrazine are prohibited. Advanced Class teams are welcome to use the competition-supplied fuel used by the Regular Class.

### **4.2.5 Fuel Tanks**

Advanced Class fuel tanks need not be accessible.

### **4.2.6 Gyroscopic Assist Allowed**

Gyroscopic assist or other forms of stability augmentation are allowed in Advanced Class.

### **4.2.7 Payload Requirements**

#### **4.2.7.1 Payload and Payload Support**

The payload must consist of a support assembly and payload plates. All payload carried for score must be carried within the

cargo bay(s). The support assembly must be constructed so as to retain the weights as a homogeneous mass. There is no required configuration for the payload plates. An example of one possible payload support configuration is provided below, but this is only an example. The design of the support assembly will depend upon the configuration of the payload plates.

The total payload consists of the plates plus the support assembly. It is the responsibility of each team to provide its own payload plates.

### **Example Payload Assembly Section**

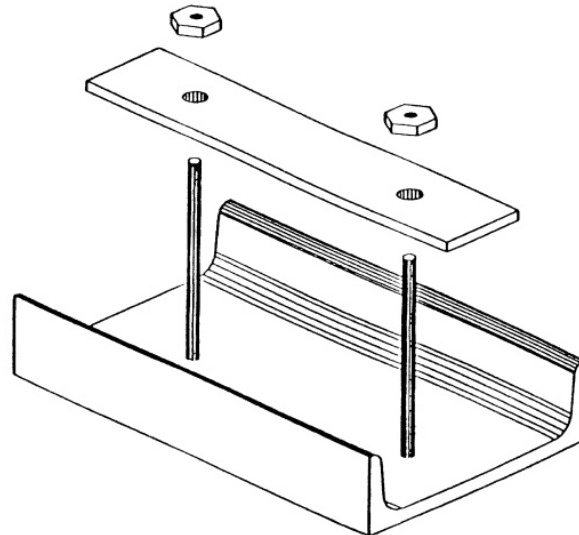

#### **4.2.7.2 Payload Distribution**

The payload cannot contribute to the structural integrity of the airframe, and must be secured to the airframe within the cargo bay so as to avoid shifting while in flight.

#### **4.2.8 Data Acquisition System (DAS)**

Advanced Class aircraft shall have either an active mechanical, electromagnetic, or optical Data Acquisition System (DAS) to measure take-off distance. Takeoff distance is defined as the distance from the starting line to when the weight of the aircraft comes off the main wheel(s), Weight-On-Wheel (WOW) = 0.

#### **4.2.9 DAS Requirements**

- DAS shall be measured in feet with precision of at least 10ths of a foot
- DAS shall use WOW as the trigger to stop recording distance traveled.
- Read-out from the DAS shall be visible from outside the aircraft.
- DAS shall have a quick reset switch.

---

#### **4.2.10 DAS Failures**

In case of a DAS failure, the DAS Takeoff Performance Term, Z, (section 40.4.4) will default to zero (0) and the flight score will only be 2 times the payload lifted. (2 x P)

### **4.3 General Requirements**

#### **4.3.1 Under Carriage**

No restrictions.

#### **4.3.2 Radios (New requirement)**

The use of 2.4 GHz radio is required for all aircraft competing in the 2010 competition.
--

#### **4.3.3 In-Flight Battery Packs**

Advanced Class aircraft must use a battery pack with capacity suitable to safely drive all the servos in the aircraft, taking into consideration the number of servos and potential current draw from those servos. Batteries may be charged at any time on the ground. Advanced Class aircraft must use a battery pack with no less than 700 mAh capacity.

#### **4.3.4 Spinners and Safety Nuts Required**

All aircraft must utilize either a spinner or a rounded safety nut.

#### **4.3.5 Metal Propellers Prohibited**

Metal propellers are not allowed.

#### **4.3.6 Control Surface Slop**

Aircraft control surfaces must not feature excessive slop. Sloppy control surfaces lead to reduced controllability in mild cases, or control surface flutter in severe cases.

#### **4.3.7 Servo Sizing**

Analysis and /or testing must be described in the Design Report that demonstrates the servos are adequately sized to handle the expected aerodynamic loads during flight.

#### **4.3.8 Qualification Flights**

Qualification flights are not required.

### **4.4 Advanced Class Scoring**

#### **4.4.1 Advanced Class Flight Score**

---

In order to participate in the flight portion of the competition, each team is required to have submitted AND received a score for both Design Report and Oral Presentation.

Advanced Class aircraft will receive a flight score based upon the DAS error, DAS Take-Off Performance, and the weight lifted.

**Flight Score = Error X (DAS Take-Off Performance) + (2 X Payload)**

$$Score = eZ + 2P$$

$$e = 1 - (D_T - D_{DAS})^2 \quad \text{eqn. 4.4.1e}$$

$$Z = 50 - \frac{(200 - D_{CTO})^2}{9}$$

#### 4.4.2 Payload Score (P)

The payload score shall be determined by multiplying the weight lifted in pounds by 2. Lifting 20 pounds will result in a payload score of 40 points.

**Payload Score = 2 x Weight Lifted in pounds**

#### 4.4.3 Error Constant (e)

The error constant shall be determined during each team's Tech-Inspection. Team MUST go through Tech-Inspection during the allotted time (the first day of the competition). Failure to have a the error constant measured during the Tech-Inspection will result in having a zero (0) constant value for the error. The distance and the type of surface to be used for obtaining error constant will be determined by each Event Director 24 hours prior to tech-inspection.

##### 4.4.3.1 Determining Error Constant

- Event Director shall announce the distance and the type of surface 24 hours prior to tech-inspection.
- Tech Inspectors will mark out a pre-determined distance on the rolling surface. This will be the measured truth Distance ( $D_T$ ) used in the error equation 4.4.3.1e.
- Team will reset their DAS to zero (0) and place the aircraft at the starting line.
- Team will roll translating their aircraft along the test track from the start line to the finish line referenced by the aircraft main wheel(s). At the end of the test, the teams will read the output from their ( $D_{DAS}$ ).

- 
- Once the tech inspection starts, the team will **NOT** be given a chance to calibrate between rolls.
  - This test shall repeat three consecutive times (3X) and the average of the three (3) rolls will determine the error constant.

$$e = 1 - (D_T - D_{DAS})^2 \quad \text{eqn. 4.4.3.1e}$$

#### 4.4.4 DAS Takeoff Performance Term (Z)

The calibrated DAS takeoff performance term,  $D_{CTO}$ , shall be determine from the distance obtained from the on-board DAS read-out .Units used for DA shall be in ft with a precision of at least 10ths of a foot.

$$Z = 50 - \frac{(200 - D_{CTO})^2}{9} \quad \text{eqn. 4.4.4.1e}$$

---

## SECTION 5.0 Micro Class Requirements

### Design Objectives:

The objective of Micro Class is to design an aircraft that can carry the highest payload fraction possible while simultaneously pursuing the lowest empty weight possible. Micro Class requires teams to make trades between two potentially conflicting requirements. Micro Class will be divided into 3 phases as follows:

Phase 1: Technical report

Teams will electronically submit their proposals for competition detailing how their design has met or exceeded the design requirements.

Phase 2: Proof of Concept Demonstrator

Phase 2A – Aircraft ease of assembly must be demonstrated (timed event).

Phase 2B – Oral Presentation on Concept Demonstrator

Phase 3: Flight Competition

Micro Class teams will be required to design and build a portable (modular based) UAV with packaging requirements and must also demonstrate its ease of assembly.

## 5.1 Aircraft Requirements and Restrictions

### 5.1.1 No lighter-than-air or rotary wing aircraft

Competing designs are limited to fixed wing aircraft only. No lighter-than-air or rotary wing aircraft such as helicopters or autogiros will be allowed to compete.

### 5.1.2 Aircraft Identification

Team number as assigned by SAE must be visible on both the top and bottom of the wing, and on both sides of the vertical stabilizer or other vertical surface in 4-inch numbers. The University name must be clearly displayed on the wings or fuselage. The University initials may be substituted in lieu of the University name provided the initials are unique and recognizable.

The assigned aircraft numbers appear next to the school name on the “Registered Teams” page of the SAE Aero Design section of the Collegiate Design Series website at:

#### Aero East:

<http://www.sae.org/students/aeroeast.htm>

#### Aero West:

<http://www.sae.org/students/aerowest.htm>

### **5.1.3 Assembly and Carrying Case**

The aircraft must be capable of assembly from a foam padded carrying case in three (3) minutes by two (2) people. See section 5.3.9

### **5.1.4 Name and Address**

Micro Class aircraft must be identified with the school name and address either on the outside or the inside of the aircraft and on the carrying case.

## **5.2 Aircraft Systems Requirements**

### **5.2.1 Engine Requirements**

Micro Class aircraft are restricted to internal combustion, reciprocating engines or electric motor propulsion. See section 5.3.1 for requirements for electric propulsion.

### **5.2.2 Propeller and Gearbox Issues**

Gearboxes in Micro Class in which the propeller RPM differs from the engine or motor RPM are allowed. Multiple engines or motors, multiple propellers, propeller shrouds, and ducted fans are allowed in Micro Class.

### **5.2.3 Competition Supplied Fuel**

Micro Class teams may provide their own fuel, but fuel for Micro Class entries must be acceptable for use by the AMA and the competition organizer. No fuel systems with gaseous boosts in which gases other than air enter the internal combustion engine will be allowed; pressurized air is also not allowed. Engines utilizing extremely hazardous fuels such as those containing tetranitromethane or hydrazine are prohibited. Micro Class teams are welcome to use the competition-supplied fuel used by the Regular Class.

### **5.2.4 Fuel Tanks**

Micro Class fuel tanks need not be accessible.

### **5.2.5 Gyroscopic Assist Allowed**

Gyroscopic assist or other forms of stability augmentation are allowed in Micro Class.

### **5.2.6 Payload Requirements**

### 5.2.6.1 Payload and Payload Support

The payload must consist of a support assembly and payload plates. All payload carried for score must be carried within the cargo bay(s). The support assembly must be constructed so as to retain the weights as a homogeneous mass. There is no required configuration for the payload plates. An example of one possible payload support configuration is provided below, but this is only an example. The design of the support assembly will depend upon the configuration of the payload plates.

The total payload consists of the plates plus the support assembly. It is the responsibility of each team to provide its own payload plates.

### Example Payload Assembly Section

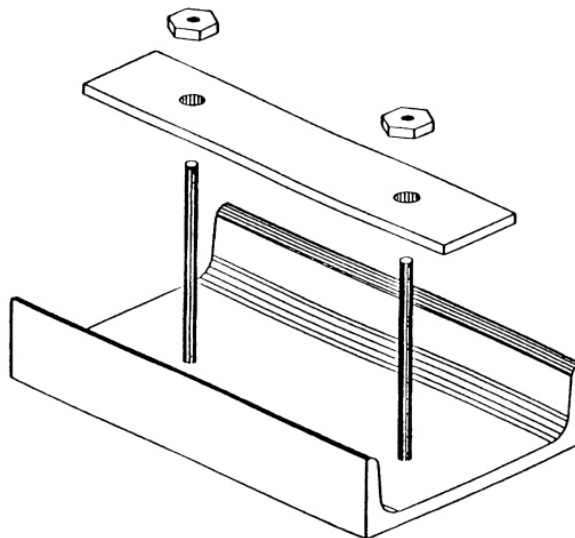

### 5.2.6.2 Payload Distribution

The payload cannot contribute to the structural integrity of the airframe, and must be secured to the airframe within the cargo bay so as to avoid shifting while in flight.

### 5.2.7 Payload Bay Limit(s)

Micro Class aircraft must be capable of carrying and fully enclosing a rectangular block measuring 8 inches by 3 inches by 4 inches. During technical inspection, compliance with this rule must be tested by inserting a block with these dimensions into the aircraft. This block must be easily inserted and removed without application of excess force during insertion or extraction, and the aircraft must be structurally airworthy with the block

---

installed. Aircraft not capable of carrying and fully enclosing the defined cargo block will be disqualified from the competition.

### **5.2.8 Payload Material**

Payload material is not limited except dimensionally. Payload materials can be in the form of plates, lead shot or similar material.

## **5.3 General Requirements**

### **5.3.1 Radios (New requirement)**

The use of 2.4 GHz radio is required for all aircraft competing in the 2010 competition.
--

### **5.3.2 In-Flight Battery Packs**

Micro Class aircraft must use a battery pack with capacity suitable to safely drive all the servos in the aircraft, taking into consideration the number of servos and potential current draw from those servos. Batteries may be charged at any time on the ground.

Micro Class aircraft utilizing electric motor propulsion are NOT allowed to use systems with Battery Eliminator Circuitry that allows a single battery pack to power both the motor and the radio equipment. The motor and the radio equipment will each have its own battery.

### **5.3.3 Spinners and Safety Nuts Required**

All aircraft must utilize either a spinner or a rounded safety nut.

### **5.3.4 Metal Propellers Prohibited**

Metal propellers are not allowed.

### **5.3.5 Control Surface Slop**

Aircraft control surfaces must not feature excessive slop. Sloppy control surfaces lead to reduced controllability in mild cases, or control surface flutter in severe cases.

### **5.3.6 Servo Sizing**

Servos must be adequately sized to handle the expected air loads during flight.

### **5.3.7 Qualification Flights**

Qualification flights are not required.

---

### 5.3.8 Aircraft Packaging General Requirements

The flight ready aircraft must be packaged in an unassembled state in a foam padded box for easy transportation and one person portability. The carrying case will contain all aircraft parts necessary for flight, including the radio transmitter, simulated fuel and/or batteries.

### 5.3.9 Aircraft Carrying Case Specifications (New)

The aircraft carrying case is a contest specified commercially available case. The case should be ordered from McMaster-Carr and is found under detail number 6589A27. Only the specified case can be used for competition and will be verified by the judges at tech inspection. Case information is listed below.

1. Carrying case outside dimensions: 19 inches by 14 inches by 6 inches.
2. Carrying case inside dimensions: 18 inches by 13 inches by 5.625 inches.
3. Carrying case approximate cost: \$70.06
4. Carrying case should contain foam cutouts to prevent items from shifting during transport.

### 5.3.10 Aircraft Propulsion Specific Requirements

For **electric propulsion aircraft only**, the propulsion battery will be packaged in its own space within the aircraft carrying case, i.e., it will NOT be pre-installed in the aircraft. The flight control battery may be pre-installed in the aircraft in its pre-determined flight position. If team elects not to pre-install the flight control battery, it must be included in the carry case in its own labeled location. During Phase 2A assembly demonstration, the propulsion system battery will not be installed for safety reasons.

For **fuel powered aircraft only**, the fuel tank will be empty during the Phase 2A demonstration assembly. A 12 ounce empty aluminum soda can must be included in the carrying case to simulate the flight necessary fuel. The flight control battery may be pre-installed in the aircraft in its pre-determined flight position. If team elects not to pre-install the flight control battery, it must be included in the carry case in its own labeled location.

## 5.4 Micro Class Scoring

In order to participate in the flight portion of the competition, each team is required to have submitted AND received a score for their Design Report and Oral Presentation.

---

#### 5.4.1 Micro Class Flight Score

The Micro Class flight score shall be determined according to the following formula:

$$\text{Flight Score} = (10 - \text{EW}) \times \text{PF} \times 13$$

Where EW = Empty Weight in pounds, and

$$\text{PF} = \text{Payload Fraction} = \frac{\text{PayloadWeight}}{\text{EmptyWeight} + \text{PayloadWeight}}$$

#### 5.4.2 Payload Prediction Bonus

No prediction points are available for Micro Class.

---

## SECTION 6.0 Design Reports and Technical Presentation

A team must have a score for their design report AND oral presentation in order to qualify for flight competition.

### 6.1 Design reports

The Design Report is the primary means in which a team is to convey to the judges how they arrived at their conclusion, that the aircraft they are entering in the competition is the aircraft most suited to perform the intended mission. The Design Report should explain the team's thought processes and engineering philosophy that drove them to their conclusions. Further, it should detail the methods, procedures, and where applicable, the calculations used to arrive at the presented solution.

The SAE Technical Paper standard is a good guideline for the Design Report, <http://www.sae.org/products/papers/paprinto/present.htm>.

Some topics that are important to cover are: selection of the overall vehicle configuration, wing plan form design including airfoil selection, drag analysis including three-dimensional drag effects, aircraft stability and control, power plant performance including both static and dynamic thrust, and performance prediction. Other topics as appropriate may be included. For more information regarding performance prediction, a white paper by Leland Nicolai is available on the Aero Design website.

The Design Report consists of the report itself, the plans, and a payload prediction graph. The signed Statement of Compliance needs to be included as page 2 of the Design Report. The Design Report must be scored with the following maximum number of points available for each section:

Report	40 Points
Plans	5 Points
<u>Prediction Graph</u>	<u>5 Points</u>
Total Design Score	50 Points

#### 6.1.1 Design Report Requirements

##### 6.1.1.1 Page Limit

The report must not exceed thirty (30) double-spaced, typewritten pages, including appendices, Cover Page, Statement of Compliance, Table of Contents, Plans, and Prediction Graph. If the design report exceeds thirty (30) pages, the judges will only read and judge the first thirty pages.

##### 6.1.1.2 Electronic Report Format

All reports will now be submitted in (.PDF) format only.

##### 6.1.1.3 Font

---

The minimum size type is 12 point proportional or a 10 character per inch non-proportional font.

**6.1.1.4 Margin**

1” Left, ½” right, top, and bottom.

**6.1.1.5 Page size**

All report pages will be ANSI A (8 1/2 x 11 inches) page format.

**6.1.1.6 Cover page**

All Design Reports must feature a cover page that states the team’s name, school, and team number. The cover page will count against the 30-page limit.

**6.1.1.7 Submission of Reports**

Teams are required to submit a PDF file emailed by the deadline date as stated in the Appendix to:

East – [AeroDesign@sae.org](mailto:AeroDesign@sae.org)

West – [AeroDesign@sae.org](mailto:AeroDesign@sae.org)

Subject line must read Design Report, Aero Design East (or West) 2009, also include your school name and number.

**6.1.2 Electronic Plan Requirements**

**6.1.2.1 Format Size**

Plan sheet must be ANSI B sized page (PDF) format (11 x 17 inches). For teams outside North America, page format size must be the closest size available to ANSI B. Plans must only consist of one (1) page, and must have the US-standard third-order projection.

**6.1.2.2 Required Views**

The plans shall consist of a standard aeronautical three-view, using a US-standard third-order projection; i.e., right side view in the lower left with the nose pointing right, top view above the right side view also with the nose pointing right, and front view in the lower right.

**6.1.2.3 Dimensions (New)**

---

At a minimum, all aircraft must have the length, width, height, and CG location clearly marked and dimensioned on the submitted engineering drawings. All dimensions must be in inches and decimal inches, to an appropriate level of precision. (**Hint: four decimal places are too many!**)

**Regular Class Aircraft:** In addition to the minimum aircraft dimensions requirements, Regular Class aircraft must call out the main wheel diameter. Failure to call out the main wheel diameter will result in a 5 point technical inspection penalty to be applied to the overall design score.

#### **6.1.2.4 Summary Data**

The plans must also contain a table with a summary of pertinent aircraft data such as wingspan, empty weight, engine make and model for Advanced Class or Micro Class, etc.

#### **6.1.2.5 Other Required Markings**

The plans must be marked with the team name, school name, and team number.

### **6.1.3 Electronic Payload Prediction Curve Requirements**

#### **6.1.3.1 Number of Copies<sup>3</sup>**

One copy of the payload prediction curve will be included with your Design Report and will count against the 30-page limit. One electronic copy of the payload prediction curve will be provided as a separate attachment (PDF), not part of the reports.

#### **6.1.3.2 Page Size**

Prediction curves must be on ANSI A sized page format (PDF) (8 ½ x 11 inches) in landscape format. For teams outside North America, page size must be the closest size available to ANSI A.

#### **6.1.3.3 Graph Markings**

The payload prediction curve (graph) must be marked with the team name and school name across the top of the graph, and with the team number marked in the bottom-right corner. The graph must include the formula used to calculate the curve.

### 6.1.3.4 Nature of the Curve

For Regular and Advanced Classes, the curve must present the payload capacity of the aircraft in pounds as a function of density altitude in feet. For Micro Class, the curve must present the payload *fraction* of the aircraft as a function of density altitude in feet. The graph must be linearized over the relevant range, and the linear equation used to predict the payload capacity or payload fraction must be clearly shown on the graph.

Only one curve, and hence one equation, may be presented on the graph. This curve may take into account predicted headwind for local conditions, rolling drag, inertia, engine and propeller performance, or any other factors that may affect takeoff performance. All these factors are allowed components of the prediction curve, but only one curve will be allowed; multiple curves to account for varying headwind conditions will not be allowed. Teams presenting multiple curves will receive no bonus points for payload prediction.

### Payload Prediction Chart – Example

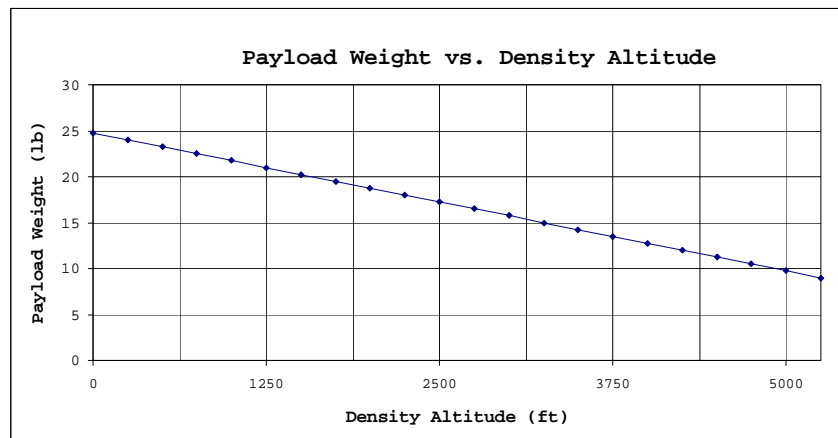

$$W_{\max} = 24.7 - (4.6 \times 10^{-4})h \text{ Density}$$

### 6.1.3.5 Scoring Precedence

In scoring the payload prediction, the equation as printed on the prediction graph will be used to calculate the prediction bonus. In the event the line as printed on the graph contradicts the equation, the equation must be used to determine the prediction bonus. Teams omitting the prediction curve equation from the prediction graph will receive no bonus points for payload prediction.

### **6.1.3.6 Micro Class Not Exempt**

Although no payload prediction bonus is available for Micro Class, Micro Class teams are still required to provide a payload prediction curve according to the guidelines described above.

### **6.1.4 Submission Deadlines**

The Design Report, plans, and payload prediction graph must be electronically submitted no later than the date indicated on the Action Deadlines given in the Appendix. Neither the Organizer nor the SAE is responsible for any lost or misdirected reports or plans. The SAE will not receive any paper copies of the reports through the mail.

## **6.2 Technical Presentations**

Each team is to give a ten (10) minute technical presentation of their design. Judging criteria for the presentation include both the quality of the technical content AND the manner in which that content is presented. During this presentation, the team should present in oral form the same information they should have provided in their Design Report (section 6.1).

As a guideline, teams should prepare for the Oral Presentation as if they were trying to convince a government customer to purchase their aircraft design instead of any competitor's design. That means a team should give a detailed explanation of how they arrived at the conclusion that their design is the best. Teams should explain why they chose their design configuration, and then present the results of any analysis or testing that was done to justify their design choices. Any aspects of the design relevant to aircraft performance should be explained.

Regular and Micro Class aircraft must be present at the Oral Presentation. Advanced Class participants should make every effort to bring all or a portion of their aircraft to the presentation; however, if the size of the aircraft prevents its display, adequate photographs are acceptable substitutes.

The Oral Presentation must be given in English, and it is worth a maximum of 50 points. Teams that exceed the 15 minute presentation time will be penalized five points against their Oral Presentation score.

Presentation Breakdown:

- 3 minutes setup
- 3 minute aircraft assembly (timed event for Micro Class only)
- 10 minute technical presentation
- 5 minute questions and answers

- 2 minute teardown

### **6.2.1 Proof of Concept Demonstrating (Micro Class)**

Micro Class aircraft have an additional requirement. Micro Class entries have to validate their ease of assembly requirement during the Oral Presentation. The aircraft must be assembled to flight ready status (minus fuel or propulsion battery) by two (2) people and actuate the flight control surfaces using the radio transmitter in three (3) minutes or less. Failure to comply will result in a 3 point deduction. For safety reasons, connection and/or installation of the propulsion battery or fuel (for fuel powered aircraft) will NOT be required or performed. It is required that the configuration presented during the assembly demonstration be the same flight configuration for flight competition. Any deviation in configuration from the assembly demonstration to the flight competition will be addressed with a design change form along with any applicable points deduction. Refer to Sections 5 for more information.

## **6.3 Technical Inspection**

### **6.3.1 Conformance to Configuration Requirements**

Technical Inspection is the event during which the aircraft are checked for compliance to the aircraft configuration requirements. Regular Class aircraft will be measured for wingspan, fit of the cargo block into the payload bay, and compliance of the engine to configuration requirements. Advanced Class aircraft will be checked for engine displacement and gross weight requirements. Any spare aircraft or spare components (major assemblies such as wings, fuselages, empennage) must be inspected with the primary competition aircraft. Micro Class has an additional item for technical inspection. All Micro Class entries must have their carrying case inspected for compliance.

### **6.3.2 Technical Inspection**

Technical Inspection will be used to assess airworthiness of entered aircraft. Items mentioned in sections 3.3, 4.3, and 5.3 will be verified, as well as any other items that could cause an aircraft to depart controlled flight. Wing warp, control surface alignment, center of gravity, and many other items will be inspected during this event.

### **6.3.3 Aircraft Conformance to Plans**

During Technical Inspection the aircraft will be inspected for conformance to the plans presented in the Design Report. All teams must have a hard copy of their design report with them during technical inspection.

#### **6.3.4 Deviation from Design**

Any deviation in construction of the aircraft since submission of the Design Report must be reported in writing. Each design change must be documented separately using FORM MOD-C. Technical Inspectors will assess penalty points obtained using the penalty chart (FORM MOD-P)

#### **6.3.5 Failure to Report Design Changes**

In the case where a team fails to report a design change, an additional 10 points will be assessed on top of each design change as discovered during tech inspection.

#### **6.3.6 Scoring the Technical Inspection**

No points are available to be scored as a result of the Technical Inspection: teams may only lose points as a result of errors and problems encountered during the inspection process. Any penalties assessed during Technical Inspection will be applied to the overall Design Report score.

### **6.4 Total Competition Scoring**

The overall competition score will be the sum of the individual components:

**Overall Score = Design Report Score + Oral Presentation Score + Flight Score**

### **6.5 Projection Equipment**

Teams planning to use data projection are responsible for bringing, or otherwise arranging for, their own data projectors. Some data projectors may be provided by the organizers; however teams should not rely on either the availability or functionality of such equipment.

### **6.6 Tie Breakers**

Tie Breakers for specific events within the competition will be decided by averaging the top three (3) flight scores.

## SECTION 7.0 Future Rule Changes

This section is intended to give teams advance notice of proposed changes to the Aero Design rules for 2011. These changes might have a significant effect on the design of the aircraft. This is an informational notice only and does not imply that the proposed change will in fact be adopted.

- Regular Class sizing and payload bay parameters will change annually.
- One of the new metrics the rules committee is considering for the Micro class is to measure endurance. This may be incorporated in future Micro-Class Competition.
- **(Now required)** With the advent of 2.4 GHz into the remote control arena, SAE is considering that 2.4 GHz radio systems be mandatory by the year 2010. This greatly reduces frequency conflicts during the flight portion of the competition and will facilitate much smoother and faster flight rounds. We realize that this imposes a financial burden on teams hence the long lead time on the notice. We welcome any input on this issue via the Aero Design Forum.

---

**Appendix**  
**2010 SAE AERO DESIGN**

**STATEMENT OF COMPLIANCE**  
**Certification of Qualification**

Team Name \_\_\_\_\_ Team Number \_\_\_\_\_

School \_\_\_\_\_

Faculty Advisor \_\_\_\_\_

Faculty  
Advisor's Email \_\_\_\_\_

**Statement of Compliance**

As Faculty Advisor, I certify that the registered team members are enrolled in collegiate courses. This team has designed, constructed and/or modified the radio controlled airplane they will use for the SAE Aero Design 2009 competition, without direct assistance from professional engineers, R/C model experts or pilots, or related professionals.

---

Signature of Faculty Advisor

**Team Captain Information:**

Team Captain:
Captain's E-mail:
Captain's Phone:

Note: A copy of this statement needs to be included in your Design Report as page 2 (see 6.1).

---

**2010 SAE AERO DESIGN EAST - ACTION DEADLINES**  
**LOCKHEED MARTIN AERONAUTICS COMPANY**  
**Fort Worth, TEXAS, USA**  
**APRIL 29-MAY 2, 2010**

- 1     **Registration**  
Register on-line at: [www.sae.org](http://www.sae.org)                   (October 5, 2009 at 10:00 AM EDT)  
Registration fee   \$600.00 USD per entry  
Registration deadline                                   December 21, 2009
  
- 2     **Design Reports, Plans, and**  
**Payload Prediction Graph**                       March 16, 2010

**DESIGN REPORTS:**

ELECTRONIC COPIES: An electronic copy of the Design Report must be received at SAE by 11:59 PM Eastern Standard Time on **Tuesday, March 16, 2010** to:  
[AeroDesign@sae.org](mailto:AeroDesign@sae.org).

You will receive an email confirmation within 48 hours of receiving your report. If you do not receive the confirmation it is your responsibility to follow up. File size must be no larger than: 1.0 MB

Subject line must read: Aero Design East Design Report, school name and number

- 3     **Rules Inquiries concerning Aero Design East Only**  
Any inquiries regarding rules or for Aero Design East 2010 will be answered by the SAE Rules Committee via the SAE Aero Design forum:  
[http://forums.sae.org/access/dispatch.cgi/aerodesign\\_pf](http://forums.sae.org/access/dispatch.cgi/aerodesign_pf)
  
- 4     **Official 2010 Aero Design East Website**  
[HTTP://WWW.SAE.ORG/STUDENTS/AEROEAST.HTM](http://www.sae.org/students/aeroeast.htm)

---

**2010 SAE AERO DESIGN WEST - ACTION DEADLINES  
LOCKHEED MARTIN AERONAUTICS COMPANY  
VAN NUYS, CALIFORNIA, USA  
MARCH 5-7, 2010**

- 1     **Registration**  
      **Register on-line at:** [www.sae.org](http://www.sae.org)                   (October 5, 2009 at 10:00 AM EST)  
      **Registration fee**   \$600.00 USD per entry  
      **Registration deadline**   December 21, 2009, 11:59 pm EST
- 2     **Design Reports, Plans, and**                                     **January 21, 2010, 11:59 EST**  
      **Payload Prediction Graph**

**DESIGN REPORTS:**

ELECTRONIC COPIES: An electronic copy of the Design Report must be received at SAE by 11:59 PM Eastern Standard Time on **Thursday, January 21, 2010** to: [AeroDesign@sae.org](mailto:AeroDesign@sae.org).

You will receive an email confirmation within 48 hours of receiving your report. If you do not receive the confirmation it is your responsibility to follow up. File size must be no larger than: 1.0 MB

Subject line must read: Aero Design West Design Report, school name and number

- 3     **Rules Inquiries concerning Aero Design West Only**  
      Any inquiries regarding rules or for Aero Design West 2010 will be answered by the SAE Rules Committee via the SAE Aero Design forum:  
      [http://forums.sae.org/access/dispatch.cgi/aerodesign\\_pf](http://forums.sae.org/access/dispatch.cgi/aerodesign_pf)
- 4     **Official 2010 Aero Design West Website**  
      [HTTP://WWW.SAE.ORG/STUDENTS/AEROWEST.HTM](http://www.sae.org/students/aerowest.htm)

---

# FORM MOD-C

**Team Number** \_\_\_\_\_

**Team Name** \_\_\_\_\_

**School:** \_\_\_\_\_

**Desired Results**

*(Describe the reason for modification and the desired results)*

**Action Taken**

*(Describe the actions or changes made to achieve the desired result)*

**Systems Affected**

*(Circle all that applies)*

Aero-Dynamics	Structural Change	Mechanical	Electronic	Misc
---------------	-------------------	------------	------------	------

**Discovery Method**

*(Describe how the problem was discovered)*

**Submitted By:** \_\_\_\_\_

# FORM MOD-P

Aero-Dynamic Changes				Structural Change (Pts Deducted)	Mechanical (Pts Deducted)	Electronic (Pts Deducted)	Misc (Pts Deducted)
Plan Form Area		Points					
Add (in <sup>2</sup> )	Removed (in <sup>2</sup> )	Add	Removed				
1		1	.5	4	3	3	2
2		1	.5	4	3	3	2
3		1	.5	4	3	3	2
4		1	.5	4	3	3	2
5		1	.5	4	3	3	2
6		2	1	4	3	3	2
7		2	1	4	3	3	2
8		2	1	4	3	3	2
9		2	1	4	3	3	2
10		4	2	4	3	3	2
11		4	2	4	3	3	2
12		4	2	4	3	3	2
13		4	2	4	3	3	2
14		4	2	4	3	3	2
15		6	3	4	3	3	2
16		6	3	4	3	3	2
17		6	3	4	3	3	2
18		6	3	4	3	3	2
19		6	3	4	3	3	2
20		8	4	4	3	3	2
21		8	4	4	3	3	2
22		8	4	4	3	3	2
23		8	4	4	3	3	2
24		8	4	4	3	3	2
25		10	5	4	3	3	2
26		10	5	4	3	3	2
27		10	5	4	3	3	2
28		10	5	4	3	3	2
29		10	5	4	3	3	2
30		12	6	4	3	3	2
31		12	6	4	3	3	2
32		12	6	4	3	3	2
33		12	6	4	3	3	2
34		12	6	4	3	3	2
35		14	7	4	3	3	2
36		14	7	4	3	3	2
37		14	7	4	3	3	2
38		14	7	4	3	3	2
39		14	7	4	3	3	2
40+		14	7	4	3	3	2