



2008 Formula SAE® Rules

NOTICE: These rules are in effect for all Formula SAE competitions held during the calendar year 2008. These rules do NOT apply to Formula SAE competitions held during 2007.

1. FORMULA SAE – OVERVIEW AND COMPETITION	9
1.1 <i>Formula SAE Competition Objective</i>	9
1.2 <i>Vehicle Design Objectives.....</i>	9
1.3 <i>Good Engineering Practices</i>	9
1.4 <i>Judging Categories</i>	9
1.5 <i>The 2008 Formula SAE Series</i>	10
1.6 <i>Official Announcements and Competition Information.....</i>	11
1.7 <i>Official Languages</i>	11
1.8 <i>Formula SAE Rules and Organizer Authority.....</i>	11
1.8.1 Rules Authority	11
1.8.2 Rules Validity	12
1.8.3 Rules Compliance	12
1.8.4 Understanding the Rules	12
1.8.5 Participating in the Competition	12
1.8.6 Violations of Intent	12
1.8.7 Right to Impound	12
1.8.8 General Authority	12
2. ELIGIBILITY	13
2.1 <i>Individual Participant Requirements.....</i>	13
2.1.1 Student Status:.....	13
2.1.2 Society Membership:	13
2.1.3 Age.....	13
2.1.4 Driver’s License.....	13
2.1.5 Liability Waiver	13
2.1.6 Medical Insurance.....	13
2.1.7 Individual Registration Requirements – ACTION REQUIRED (New for 2008).....	13
2.1.8 Faculty Advisor.....	15
2.2 <i>Registration Requirements</i>	15
2.2.1 Vehicle Eligibility	15
2.2.2 The Formula SAE Competition Year.....	15
2.2.3 Registration – North American Formula SAE Competitions.....	16
2.2.3.1 First Year Vehicles – North American Formula SAE Competitions	16
2.2.3.2 Second Year Vehicles – North American Formula SAE Competitions	16
2.2.3.3 Entries per University - North American Formula SAE Competitions - One per Competition	16
2.2.3.4 Registration Limits - North American Formula SAE Competitions	16
2.2.3.5 Registration Dates – North American Formula SAE Competitions.....	16
2.2.4 Formula SAE Australia, Formula SAE Brasil, Formula SAE Italy, and Formula Student	17
2.2.4.1 First Year Vehicles: FSAE-A, FSAE-B, FSAE-I and Formula Student	17
2.2.4.2 Second Year Vehicles: FSAE-A, FSAE-B, FSAE-I and Formula Student	17
2.2.4.3 Third Year Vehicles –Prohibited.....	18
2.2.4.4 Registration Fees.....	18
2.2.5 Documentation Photographs	18



DAIMLERCHRYSLER GM/SAE/Chrysler FORMULA SAE



2.2.5.1 Documentation Photograph Format 18
 2.2.6 Withdrawals 19
 2.2.7 United States Visas 19

3. VEHICLE REQUIREMENTS & RESTRICTIONS 20

3.1 General Design Requirements 20
 3.1.1 Body and Styling..... 20
 3.1.2 Wheelbase and Vehicle Configuration..... 20
 3.1.3 Vehicle Track..... 20
 3.1.4 Visible Access..... 20
3.2 Chassis Rules..... 20
 3.2.1 Suspension 20
 3.2.2 Ground Clearance 21
 3.2.3 Wheels and Tires..... 21
 3.2.3.1 Wheels..... 21
 3.2.3.2 Tires 21
 3.2.4 Steering 21
 3.2.5 Brake Systems..... 22
 3.2.5.1 Brake Test 22
 3.2.5.2 Brake Over Travel Switch..... 22
 3.2.5.3 Brake Light 22
 3.2.6 Jacking Points 23
3.3 Structural Requirements 23
 3.3.1 Definitions..... 23
 3.3.2 Structural Equivalency and Structural Equivalency Form (SEF)..... 24
 3.3.2.1 Structural Equivalency Form – Submission 24
 3.3.3 Minimum Material Requirements 25
 3.3.3.1 Baseline Steel Material 25
 3.3.3.2 Alternative Tubing and Material 25
 3.3.3.2.1 General 25
 3.3.3.2.2 Steel Tubing Requirements 26
 3.3.3.2.3 Aluminum Tubing Requirements..... 26
 3.3.3.2.4 Composite Materials 26
 3.3.4 Roll Hoops 27
 3.3.4.1 Main and Front Hoops – General Requirements 28
 3.3.4.2 Main Hoop 28
 3.3.4.3 Front Hoop 29
 3.3.5 Roll Hoop Bracing 29
 3.3.5.1 Main Hoop Bracing..... 29
 3.3.5.2 Front Hoop Bracing..... 30
 3.3.5.3 Other Bracing Requirements..... 30
 3.3.5.4 Other Side Tube Requirements 31
 3.3.5.5 Mechanically Attached Roll Hoop Bracing 31
 3.3.6 Frontal Impact Structure 32
 3.3.6.1 Bulkhead 32
 3.3.6.2 Front Bulkhead Support 32
 3.3.6.3 Impact Attenuator 33
 3.3.6.4 Impact Attenuator Data Requirement..... 33
 3.3.6.5 Non-Crushable Objects 34
 3.3.7 Front Bodywork 34
 3.3.8 Side Impact Structure..... 34
 3.3.8.1 Tube Frames..... 34
 3.3.8.2 Composite Monocoque 35



DAIMLERCHRYSLER GM/SAE/Chrysler FORMULA SAE



3.3.8.3 Metal Monocoque	35
3.3.9 Inspection Holes.....	36
<i>3.4 Driver and Cockpit Equipment.....</i>	<i>36</i>
3.4.1 Driver Restraint System	36
3.4.2 Driver’s Equipment.....	39
3.4.2.1 Helmet.....	39
3.4.2.2 Suit	40
3.4.2.3 Gloves	40
3.4.2.4 Goggles or Face Shields.....	40
3.4.2.5 Shoes	40
3.4.2.6 Arm Restraints	40
3.4.2.7 Hair Covering.....	41
3.4.3 Driver Visibility	41
3.4.3.1 General Requirement	41
3.4.3.2 Mirrors	41
3.4.4 Head Restraint and Roll bar Padding	41
3.4.5 Floor Closeout.....	41
3.4.6 Steering Wheel.....	42
3.4.6.1 Circular Shape.....	42
3.4.6.2 Quick Disconnect.....	42
3.4.7 Driver Egress.....	42
3.4.8 Roll Over Stability	42
3.4.8.1 Tilt Table.....	42
3.4.9 Master Switches	42
3.4.9.1 Primary Master Switch.....	42
3.4.9.2 Cockpit-mounted Master Switch.....	43
3.4.10 Fire Protection.....	44
3.4.10.1 Firewall	44
3.4.10.2 Fire Extinguishers	44
3.4.11 Batteries	44
3.4.12 Accessibility of Controls.....	45
3.4.13 Seat.....	45
3.4.14 Driver’s Leg Protection.....	45
<i>3.5 Powertrain.....</i>	<i>45</i>
3.5.1 Engine and Drivetrain	45
3.5.1.1 Engine Limitations.....	45
3.5.1.2 Engine Inspection.....	45
3.5.1.3 Transmission and Drive	46
3.5.1.4 Drive Train Shields and Guards.....	46
3.5.1.5 System Sealing.....	46
3.5.1.6 Coolant Fluid Limitations	46
3.5.1.7 Starter	46
3.5.2 Fuels.....	47
3.5.2.1 Fuel Temperature Changes – Prohibited.....	47
3.5.2.2 Fuel Additives – Prohibited	47
3.5.3 Fuel System.....	47
3.5.3.1 Fuel Tank Size Limit.....	47
3.5.3.2 Filler Neck & Sight Tube	47
3.5.3.3 Fuel Level Line	48
3.5.3.4 Tank Filling Requirement	48
3.5.3.5 Spillage Prevention	48
3.5.3.6 Venting Systems	49
3.5.3.6.1 Tilt Test-Fuel and Fluids.....	49
3.5.3.7 Fuel Lines, Line Attachment and Protection.....	49



DAIMLERCHRYSLER GM/SAE/Chrysler FORMULA SAE

3.5.3.8 Fuel Injection System Requirement	49
3.5.3.9 Air Intake and Fuel System Location Requirements	50
3.5.4 Throttle, Throttle Actuation and Intake Restrictor	50
3.5.4.1 Carburetor/Throttle Body – Required	50
3.5.4.2 Throttle Actuation	50
3.5.4.3 Intake System Restrictor	51
3.5.4.4 Turbochargers & Superchargers.....	51
3.5.5 Muffler and Exhaust System.....	51
3.5.5.1 Muffler	51
3.5.5.2 Exhaust Outlet.....	52
3.5.5.3 Noise	52
3.6 Vehicle Identification.....	52
3.6.1 Car Number.....	52
3.6.2 School Name	53
3.6.3 SAE Logo.....	53
3.6.4 Technical Inspection Sticker Space.....	53
3.7 General.....	54
3.7.1 Aero Dynamics and Ground Effects	54
3.7.1.1 Location	54
3.7.1.2 Driver Egress Requirements	54
3.7.1.3 Wing Edges - Minimum Radii	54
3.7.1.4 Other Edge Radii Limitations	54
3.7.1.5 Wing Edge Restrictions.....	54
3.7.1.6 Ground Effect Devices – Prohibited	54
3.7.2 Fasteners	55
3.7.2.1 Grade Requirements.....	55
3.7.2.2 Securing Fasteners	55
3.7.3 Modifications and Repairs	55
3.7.4 Compressed Gas Cylinders and Lines.....	56
3.7.5 High Pressure Hydraulic Pumps and Lines.....	56
3.8 Transponders.....	57
3.8.1 Transponders – North American FSAE competitions.....	57
3.8.2 Transponder Requirement	57
3.8.3 Transponder mounting	57
4. STATIC EVENTS	59
4.1 Static Events	59
4.2 Technical Inspection.....	59
4.2.1 Objective	59
4.2.2 Inspection & Testing Requirement	59
4.2.3 Inspection Condition	60
4.2.4 Inspection Process.....	60
4.2.5 Correction and Re-inspection.....	60
4.2.6 Inspection Stickers	60
4.3 Cost & Manufacturing Analysis Event	61
4.3.1 The Concept	61
4.3.2 The Requirements	61
4.3.2.1 Formula SAE, Formula SAE at VIR & Formula SAE West Cost Reports	61
4.3.3 Scoring	62
4.3.4 The Cost Report	62
4.3.4.1 General Requirements.....	64
4.3.4.2 Receipts.....	64



DAIMLERCHRYSLER GM/SAE/COMPAGNY FORD/MOTOR



- 4.3.4.3 Report Submission and Deadline 64
- 4.3.4.4 Late Submission of Cost Report..... 65
- 4.3.4.5 Addenda 65
- 4.3.4.6 Cost Report Judging and Penalties..... 65
- 4.3.5 Discussion at the Competition 66
- 4.3.6 Cost Calculations 66
- 4.3.6.1 Component Costs 66
- 4.3.6.2 Labor and Assembly Costs..... 67
- 4.3.7 Cost Report Exempt Items 67
- 4.3.7.1 Finishes 67
- 4.3.7.2 Fire Extinguisher and Suppression System 68
- 4.3.7.3 Tires and Wheels..... 68
- 4.3.7.4 Transponders, Data Acquisition, Video and Radio Systems..... 68
- 4.3.8 Engine Costing..... 68
- 4.3.9 Costing Tables..... 69
- 4.3.10 Examples of Process Descriptions 70
- 4.3.10.1 Purchase Example 70
- 4.3.10.2 Purchased and Altered Example 70
- 4.3.10.3 Manufactured Example 71
- 4.3.10.4 Off-Line Assembly Example 72
- 4.3.11 Exchange Rates 72
- 4.3.12 Taxes 72
- 4.4 *Presentation Event*..... 73
- 4.4.1 Presentation Event Objective – Business Case 73
- 4.4.2 Presentation Schedule 73
- 4.4.3 Presentation Format 73
- 4.4.3.1 Data Projection Equipment 73
- 4.4.4 Evaluation Criteria 74
- 4.4.5 Scoring Formula..... 74
- 4.5 *Design Event*..... 75
- 4.5.1 Design Event Objective..... 75
- 4.5.2 Design Report and Design Spec Sheet – Submission Requirements 75
- 4.5.2.1 Vehicle Drawings..... 76
- 4.5.3 Design Report and Design Spec Sheet Formats 76
- 4.5.4 Excess Size Design Reports 76
- 4.5.5 Submission Deadlines 76
- 4.5.6 Penalty for Late Submission or Non-Submission 77
- 4.5.7 Penalty for Unsatisfactory Submissions..... 77
- 4.5.8 Design Event – Vehicle Condition..... 77
- 4.5.9 Judging Criteria..... 77
- 4.5.10 Judging Sequence..... 77
- 4.5.11 Scoring 78
- 4.5.12 Photographic Requirements 78
- 4.5.13 Second Year Cars - Penalties For Insufficient Redesign..... 78

5. DYNAMIC EVENTS 79

- 5.1 *Dynamic Events*..... 79
- 5.1.1 Vehicle Integrity and Disqualification 79
- 5.2 *Weather Conditions*..... 79
- 5.2.1 Running in Rain 79
- 5.2.1.1 Operating Conditions 79
- 5.2.1.2 Decision on Operating Conditions 79
- 5.2.1.3 Notification 80



DAIMLERCHRYSLER GM/SAE/Chrysler FORMULA SAE



5.2.1.4 Tire Requirements	80
5.2.1.5 Event Rules	80
5.2.1.6 Penalties	80
5.2.1.7 Scoring	80
5.2.1.8 Tire Changing	80
<i>5.3 Driver Limitations</i>	<i>82</i>
<i>5.4 Acceleration Event.....</i>	<i>83</i>
5.4.1 Acceleration Objective.....	83
5.4.2 Acceleration Procedure	83
5.4.3 Acceleration Heats	83
5.4.4 Tire Traction – Limitations	83
5.4.5 Acceleration Scoring.....	83
5.4.5.1 Cones Down Or Out (DOO)	83
5.4.5.2 Off Course.....	83
5.4.6 Acceleration Scoring Formula	84
<i>5.5 Skid-Pad Event</i>	<i>85</i>
5.5.1 Skid-Pad Objective	85
5.5.2 Skid-Pad Heats.....	85
5.5.3 Skid-Pad Heat Priority	85
5.5.4 Skid-Pad Layout.....	85
5.5.5 Skid-Pad Layout – Marking	86
5.5.6 Skid-Pad Procedure.....	86
5.5.7 Skid-Pad Penalties.....	87
5.5.7.1 Cones Down Or Out (DOO)	87
5.5.7.2 Off Course.....	87
5.5.7.3 Incorrect Laps	87
5.5.8 Skid-Pad Scoring.....	87
<i>5.6 Autocross Event.....</i>	<i>88</i>
5.6.1 Autocross Objective	88
5.6.2 Autocross Procedure	88
5.6.3 Autocross Course Specifications & Speeds	88
5.6.4 Autocross Penalties	88
5.6.4.1 Cone Down or Out (DOO).....	89
5.6.4.2 Off Course.....	89
5.6.4.3 Missed Slalom.....	89
5.6.5 Stalled & Disabled Vehicles	89
5.6.6 Corrected Elapsed Time.....	89
5.6.7 Best Run Scored.....	89
5.6.8 Autocross Scoring Formula.....	89
<i>5.7 Endurance and Fuel Economy Event.....</i>	<i>91</i>
5.7.1 Right to Change Procedure	91
5.7.2 Endurance Objective—350 points	91
5.7.3 Fuel Economy—50 points.....	91
5.7.4 Endurance Course Specifications & Speeds	91
5.7.5 Endurance General Procedure.....	92
5.7.6 Endurance Fuel Fill.....	92
5.7.7 Endurance Vehicle Starting/ Restarting	92
5.7.8 Endurance Driver Change Procedure.....	92
5.7.9 Entering the Track.....	93
5.7.10 Endurance Run Order.....	93
5.7.11 Breakdowns & Stalls.....	93
5.7.12 Endurance Minimum Speed Requirement	93



DAIMLERCHRYSLER GM/SAE/Chrysler FORMULA SAE



5.7.13 Exiting the Course..... 93

5.7.14 Endurance Lap Timing..... 94

5.7.15 Endurance Penalties 94

5.7.15.1 Cones..... 94

5.7.15.2 Off Course (OC)..... 94

5.7.15.3 Missed Slalom..... 94

5.7.15.4 Penalties for Moving Violations 94

5.7.15.5 Out of Order 95

5.7.15.6 Mechanical Problem..... 95

5.7.15.7 Reckless or Aggressive Driving..... 95

5.7.15.8 Inexperienced Driver..... 95

5.7.15.9 Poor Fuel Economy 95

5.7.16 Endurance Scoring 95

5.7.17 Endurance Scoring Formula..... 96

5.7.18 Fuel Economy 96

5.7.19 E85 Correction Factor 96

5.7.20 Fuel Economy Scoring Formula 96

5.7.21 Post Event Engine Check 97

5.7.22 Endurance and Fuel Economy Scoring with Two Heats..... 97

5.8 *Flags*..... 97

5.8.1 Command Flags 97

5.8.2 Informational Flags 98

5.9 *Rules of Conduct*..... 98

5.9.1 Competition Objective – A Reminder..... 98

5.9.2 Unsportsmanlike Conduct..... 99

5.9.3 Official Instructions 99

5.9.4 Arguments with Officials..... 99

5.9.5 Alcohol and Illegal Material 99

5.9.6 Parties..... 99

5.9.7 Trash Clean-up..... 99

5.10 *General Rules*..... 99

5.10.1 Dynamometer Usage..... 99

5.10.2 Problem Resolution..... 100

5.10.3 Protests..... 100

5.10.4 Forfeit for Non-Appearance..... 100

5.10.5 Drivers Meetings – Attendance Required 100

5.10.6 Personal Vehicles 100

5.10.7 Motorcycles, Bicycles, Rollerblades, etc.—Prohibited..... 101

5.10.8 Self-propelled Pit Carts, Tool Boxes, etc. - Prohibited 101

5.11 *Pit Rules*..... 101

5.11.1 Vehicle Movement 101

5.11.2 Push Bar 101

5.11.3 Smoking – Prohibited..... 101

5.11.4 Fueling and Refueling 101

5.11.5 Engine Running in the Paddock..... 101

5.12 *Driving Rules*..... 102

5.12.1 Driving Under Power 102

5.12.2 Driving Off-site..... 102

5.12.3 Practice Track 102

5.12.4 Situational Awareness..... 102

5.12.5 Endurance Event – Driving..... 102

5.12.6 Endurance Event – Passing..... 103



5.12.7 Endurance Event – Driver’s Course Walk	103
5.13 Definitions	103
6. NOTICE OF POSSIBLE RULE CHANGES FOR THE 2009 FORMULA SAE SERIES.....	104
7. QUESTIONS ABOUT THE FORMULA SAE RULES.....	107
7.1 Frequently Asked Questions	107
7.2 Question Format.....	107
7.3 Response Time	107
7.4 Submission Addresses:	107
8. IMPORTANT FORMS AND DOCUMENTS	108
APPENDIX A-1	109
APPENDIX A-2	110
APPENDIX A- 3	111
APPENDIX A- 4	114
APPENDIX A- 5	115
APPENDIX A- 6	116
APPENDIX A- 7	117
APPENDIX A- 8	118



2008 Formula SAE Rules

1. FORMULA SAE – OVERVIEW AND COMPETITION

1.1 Formula SAE Competition Objective

The Formula SAE® Series competitions challenge teams of university undergraduate and graduate students to conceive, design, fabricate and compete with small, formula style, autocross racing cars. To give teams the maximum design flexibility and the freedom to express their creativity and imaginations there are very few restrictions on the overall vehicle design. Teams typically spend eight to twelve months designing, building, testing and preparing their vehicles before a competition. The competitions themselves give teams the chance to demonstrate and prove both their creativity and their engineering skills in comparison to teams from other universities around the world.

1.2 Vehicle Design Objectives

For the purpose of this competition, the students are to assume that a manufacturing firm has engaged them to design, fabricate and demonstrate a prototype car for evaluation as a production item. The intended sales market is the nonprofessional weekend autocross racer. Therefore, the car must have very high performance in terms of its acceleration, braking, and handling qualities. The car must be low in cost, easy to maintain, and reliable. It should accommodate drivers whose stature varies from a 5th percentile female to a 95th percentile male. In addition, the car's marketability is enhanced by other factors such as aesthetics, comfort and use of common parts. The manufacturing firm is planning to produce four (4) cars per day for a limited production run and the prototype vehicle should actually cost below \$25,000. The challenge to the design team is to develop a prototype car that best meets these goals and intents. Each design will be compared and judged with other competing designs to determine the best overall car.

1.3 Good Engineering Practices

Vehicles entered into Formula SAE competitions are expected to be designed and fabricated in accordance with good engineering practices.

1.4 Judging Categories

The cars are judged in a series of static and dynamic events including: technical inspection, cost, presentation, and engineering design, solo performance trials, and high performance track endurance. These events are scored to determine how well the car performs. In each event, the manufacturing firm has specified minimum acceptable performance levels that are reflected in the scoring equations.



The following points are possible:

Static Events		
	Presentation	75
	Engineering Design	150
	Cost Analysis	100
Dynamic Events		
	Acceleration	75
	Skid-Pad	50
	Autocross	150
	Fuel Economy	50
	Endurance	350
<hr/>		
Total Points		1,000

1.5 The 2008 Formula SAE Series

The 2008 Formula SAE Series consists of the following seven (7) competitions:

1. Formula SAE held in Michigan, USA and organized by SAE
2. Formula SAE West held in California, USA and organized by SAE
3. Formula SAE at VIR held in Virginia, USA and sponsored by SAE
4. Formula SAE Australasia held in Australia and organized by SAE Australasia
5. Formula SAE Brasil held in Brasil and organized by SAE Brasil
6. Formula SAE Italy held in Italy and organized by ATA
7. Formula Student held in the United Kingdom and organized by IMechE

All Formula SAE competitions have open registration policies and accept registrations by student teams representing universities in any country.

Formula SAE Australasia, Formula SAE Brasil, Formula SAE Italy and Formula Student may post some minor rule variations specific to the operation of the events in their countries, however, the vehicle design requirements and restrictions will remain unchanged. Any rule variations will be posted on the websites specific to those competitions.

Note on FSAE at VIR – 2008 Formula SAE at VIR (Virginia International Raceway) is being held to assess the level of support for a third competition in North America. The response to, and outcome of, this competition will help us decide if a third event should be added to the future schedule.



1.6 Official Announcements and Competition Information

Teams are required to read the newsletters published by SAE and the other organizing bodies and to be familiar with all official announcements concerning the competitions and rules interpretations released by the FSAE Rules Committee.

The monthly SAE Collegiate Design Newsletter is published online and can be found at: <http://www.sae.org/students/collegiate/newsletters.htm>

The FSAE Australasia Newsletter is published online and can be found at: <http://www.sae-a.com.au/fsae/index.htm>

1.7 Official Languages

The official language of the Formula SAE series is English. Document submissions, presentations and discussions in English are acceptable at all competitions in the series.

Team members, judges, and officials at FSAE Brasil and FSAE Italy may use their respective national languages for document submissions, presentations and discussions if all the parties involved agree to the use of that language.

The languages in use at the competitions of Formula SAE series are:

- Formula SAE - English
- Formula SAE West - English
- Formula SAE at VIR - English
- Formula SAE Australasia - English
- Formula SAE Brasil - Portuguese and English
- Formula SAE Italy - Italian and English
- Formula Student - English

1.8 Formula SAE Rules and Organizer Authority

1.8.1 Rules Authority

The Formula SAE Rules are the responsibility of the Formula SAE Rules Committee and are issued under the authority of the SAE University Programs Committee. Official announcements from the Formula SAE Rules Committee, SAE or the other Formula SAE organizing bodies shall be considered part of, and shall have the same validity as, these rules.

Ambiguities or questions concerning the meaning or intent of these rules will be resolved by the Formula SAE Rules Committee, SAE or by the individual competition organizers as appropriate.



1.8.2 Rules Validity

The Formula SAE Rules posted on the SAE website and dated for the calendar year of the competition are the rules in effect for the competition. Rule sets dated for other years are invalid.

1.8.3 Rules Compliance

By entering a Formula SAE competition the team, members of the team as individuals, faculty advisors and other personnel of the entering university agree to comply with, and be bound by, these rules and all rule interpretations or procedures issued or announced by SAE, the Formula SAE Rules Committee and the other organizing bodies. All team members, faculty advisors and other university representatives are required to cooperate with, and follow all instructions from, competition organizers, officials and judges.

1.8.4 Understanding the Rules

Teams, team members as individuals and faculty advisors, are responsible for reading and understanding the rules in effect for the competition in which they are participating. The section and paragraph headings in these rules are provided only to facilitate reading: they do not affect the paragraph contents.

1.8.5 Participating in the Competition

Teams, team members as individuals, faculty advisors and other representatives of a registered university who are present on-site at a competition are considered to be “participating in the competition” from the time they arrive at the event site until they depart the site at the conclusion of the competition or earlier by withdrawing.

1.8.6 Violations of Intent

The violation of intent of a rule will be considered a violation of the rule itself. Questions about the intent or meaning of a rule may be addressed to the Formula SAE Rules Committee or by the individual competition organizers as appropriate.

1.8.7 Right to Impound

SAE and other competition organizing bodies reserve the right to impound any onsite registered vehicles at any time during a competition for inspection and examination by the organizers, officials and technical inspectors.

1.8.8 General Authority

SAE and the competition organizing bodies reserve the right to revise the schedule of any competition and/or interpret or modify the competition rules at any time and in any manner that is, in their sole judgment, required for the efficient operation of the event or the Formula SAE series as a whole.



2. ELIGIBILITY

2.1 Individual Participant Requirements

Eligibility is limited to undergraduate and graduate students to insure that this is an engineering competition rather than a race. Individual members of teams participating in this competition must satisfy the following requirements:

2.1.1 Student Status:

Team members must be enrolled as degree seeking undergraduate or graduate students in a college or university. Team members who have graduated during the seven (7) month period prior to the competition remain eligible to participate.

2.1.2 Society Membership:

Team members must be members of at least one of the following societies: (1) SAE, (2) SAE Australasia, (3) SAE Brasil, (4) ATA or (5) IMechE. Proof of membership, such as membership card, is required at the competition.

Note: Students can join SAE online at: www.sae.org/students

2.1.3 Age

Team members must be at least eighteen (18) years of age.

2.1.4 Driver's License

Team members who will drive a competition vehicle at any time during a competition must hold a valid, government issued driver's license.

2.1.5 Liability Waiver

All on-site participants, including students, faculty and volunteers, are required to sign a liability waiver upon registering on-site.

2.1.6 Medical Insurance

Individual medical insurance coverage is required and is the sole responsibility of the participant.

2.1.7 Individual Registration Requirements – ACTION REQUIRED (New for 2008)

All participating team members and faculty advisors must be sure that they are individually linked to their respective school / college / university on the SAE website. You can confirm or correct your school / college / university affiliation by going to www.sae.org and logging into “MySAE” with your username and password. If you do not have a current username, you will need to create one by selecting the “Need a User ID and Password to Login?” link. If you are already an



SAE member, select the “MyMember Info” button and then select the “Update School Information” link. You will then be prompted to update your education information.

If you are not an SAE member, go to www.sae.org and select the “Join SAE / Membership Renewal” link under “Quicklinks”, then select the “Join SAE” link under “Join SAE International”. Students will need to select the “Student Membership” link and then follow the series of the questions that are asked. Faculty that wishes to be SAE members should choose the “Professional Membership” link and proceed to the series of questions. Please note all student participants must be an SAE member to participate in the event.

Once you’ve obtained an SAE member number and have linked yourself to your respective school, all affiliated students must complete the following information on the SAE website:

Medical insurance (provider, policy/ID number, telephone number)

Driver’s license (state/country, ID number)

Emergency contact data (point of contact (parent/guardian, spouse), relationship, and phone number)

To do this you will need to go to Student Central on the SAE homepage, then click on the “2008 Competition Date and Registration Information” link under “Student Competitions”. Proceed by selecting the “Competition Schedule/Registration” link and then the event(s) you wish to register for. Choose the “Register” link (or “Update” link if after December 27, 2007) next to your desired competition(s) and then select your team link to add yourself to the team profile. The “Add New Member” button will allow individuals to include themselves with the rest of the team.

PLEASE BRING YOUR OFFICIAL DRIVER’S LICENSE OR PASSPORT TO ONSITE REGISTRATION. ALSO PLEASE BRING MEDICAL INSURANCE CARD.

All international student participants (or unaffiliated faculty advisors) who are not SAE members are required to complete the International Student Registration form for the entire team found under “Competition Resources” on the event specific webpage. Upon completion, email the form to CollegiateCompetitions@sae.org.

All students, both domestic and international, must affiliate themselves online or submit the International Student Registration form by February 28, 2008. For additional assistance, please contact CollegiateCompetitions@sae.org.

****NOTE: When your team is registering for a competition, only the student or faculty advisor completing the registration needs to be linked to the school. All other students and faculty can affiliate themselves after registration has been completed, however this must be done on or before February 28, 2008.**



2.1.8 Faculty Advisor

Each team is expected to have a Faculty Advisor appointed by the university. The Faculty Advisor is expected to accompany the team to the competition and will be considered by competition officials to be the official university representative.

Faculty Advisors may advise their teams on general engineering and engineering project management theory, but may not design any part of the vehicle nor directly participate in the development of any documentation or presentation. Additionally,

Faculty Advisors may neither fabricate nor assemble any components nor assist in the preparation, maintenance, testing or operation of the vehicle.

In Brief – Faculty Advisors may not design, build or repair any part of the car.

2.2 Registration Requirements

2.2.1 Vehicle Eligibility

Vehicles entered into Formula SAE competitions must be conceived, designed, fabricated and maintained by the student team members without direct involvement from professional engineers, automotive engineers, racers, machinists or related professionals.

The student team may use any literature or knowledge related to car design and information from professionals or from academics as long as the information is given as a discussion of alternatives with their pros and cons. Professionals may not make design decisions or drawings and the Faculty Advisor must sign a statement of compliance with this restriction.

It is the intent of the SAE Collegiate Design Series competitions to provide direct hands-on experience to the students. Therefore, students should perform all fabrication tasks whenever possible.

2.2.2 The Formula SAE Competition Year

For the purpose of defining first, second and third year cars, a competition “year” is any consecutive run of the Series, i.e. Formula SAE, Formula SAE West, Formula SAE at VIR, Formula Student, Formula SAE Italy, Formula SAE Brasil, and Formula SAE Australasia held within a roughly 12 month period counting from the event in which a vehicle first competes. For example, a car that competes first in Formula SAE Australasia is classified as a “first year car” until the following year’s Formula SAE Australasia competition.

Note: Teams are reminded that their vehicles must comply with the rules in effect for each competition they enter.



2.2.3 Registration – North American Formula SAE Competitions

Registration for Formula SAE competitions held in North America must be completed on-line. Online registration must be done by either (a) an SAE member or (b) the official faculty advisor connected with the registering university and recorded as such in the SAE record system.

Note: It typically takes at least 1 working day between the time you complete an on-line SAE membership application and our system recognizes you as eligible to register your team.

2.2.3.1 First Year Vehicles – North American Formula SAE Competitions

Only first year vehicles may enter the Formula SAE Competitions in North America.

To be classified as a “first year vehicle” a car must, as a minimum, have a completely new frame. Photographic or other evidence will be used to determine if the frame is new. If there is any question about whether or not the car is in fact a first year vehicle, it will be the sole responsibility of the team to produce such evidence as the organizers or judges may require.

2.2.3.2 Second Year Vehicles – North American Formula SAE Competitions

Vehicles that have competed during any previous Formula SAE year are prohibited from Formula SAE competitions held in North America.

2.2.3.3 Entries per University - North American Formula SAE Competitions - One per Competition

Registration into Formula SAE competitions held in North America is limited to one (1) vehicle per university per competition depending on available space.

2.2.3.4 Registration Limits - North American Formula SAE Competitions

Registration into the North American Formula SAE competitions is limited as follows:

Formula SAE	120 teams
Formula SAE West	80 teams
Formula SAE VIR	50 teams

Registration for each FSAE competitions closes as soon as the registration limit is reached. We strongly advise teams to register as soon as registration opens.

2.2.3.5 Registration Dates – North American Formula SAE Competitions

Registration for the North American Formula SAE competitions will open at 10:00 am EDT, Monday, October 1, 2007.



For the first month of the registration period a team may enter either FSAE or FSAE West, but not both. During that period the team may also register for FSAE at VIR.

Specifically, from 10:00 am EDT, Monday, October 1, 2007 until 9:59 am Monday, November 5, 2007, teams may register for any one of the following: (a) Formula SAE alone, (2) Formula SAE West alone, (c) Formula SAE at VIR alone, (d) Formula SAE and Formula SAE at VIR, or (e) Formula SAE West and Formula SAE at VIR.

After the first month of registration any untaken slots at any of the competitions will be available to any team on a first come, first serve basis.

Specifically from 10:00 am EDT, Thursday, November 1, 2007, until the close of registration at 11:59 pm December 27, 2007 teams may register for any competition in which registration slots are available.

Registration for the North American Formula SAE competitions will close at 11:59 pm EST, Thursday December 27, 2007 or when all the registration slots have been taken, whichever occurs first.

There is no late registration and there are no exceptions to this registration policy.

Note – Teams planning to enter FSAE at VIR are urged to read the information on this competition on the CDS website and in Appendix A - 8.

2.2.4 Formula SAE Australia, Formula SAE Brasil, Formula SAE Italy, and Formula Student

Note: Check the individual competition websites for exact registration requirements, applicable to those events.

2.2.4.1 First Year Vehicles: FSAE-A, FSAE-B, FSAE-I and Formula Student

To be classified as a “first year vehicle” a car must, as a minimum, have a completely new frame. Photographic or other evidence will be used to determine if the frame is new. If there are any questions about whether or not the car is in fact a first year vehicle, it will be the sole responsibility of the team to produce such evidence as the organizers or judges may require.

2.2.4.2 Second Year Vehicles: FSAE-A, FSAE-B, FSAE-I and Formula Student

Vehicles that have competed during any one (1) previous Formula SAE year may compete provided that they have been substantially modified from their first appearance. Photographic and design documentation detailing the modifications are required along with a statement from the team’s Faculty Advisor.

Penalties for insufficient redesign or insufficient knowledge by the team will be applied during the Design Event. Refer to the section 4.5.13 “Penalties for Insufficient Redesign”.



2.2.4.3 Third Year Vehicles –Prohibited

Vehicles that have competed in any two (2) previous Formula SAE years are prohibited from participating in any Formula SAE competition.

Any team found to have entered a vehicle that contravenes this rule will be disqualified. Additionally, the team will be required to submit such documentation as the organizers may require in advance of the acceptance of any future registration.

2.2.4.4 Registration Fees

Registration fees must be paid to the organizer by the deadline specified on the respective competition website.

Registration fees are not refundable.

2.2.5 Documentation Photographs

Teams must bring with them to the competition and give to the organizers, a series of pairs of color photographs comparing (a) various design elements of their current vehicle with (b) the same features of the team's most recent previous entry. The comparison photograph pairs must include at least the following views of each entry:

- (1) Overall car in $\frac{3}{4}$ view,
- (2) Driver compartment,
- (3) Foot box including pedals,
- (4) Engine including intake,
- (5) Drive train,
- (6) Front suspension on one side including the wheel upright,
- (7) Rear suspension on one side including the wheel upright and
- (8) Rear view of the vehicle.

Removable body panels must be removed for these photographs. Aero devices, if any, must be covered by additional photographs. Teams may, at their option, include additional pairs of comparison photographs.

These photographs are to be given to the organizers at on-site Registration.

Rookie teams are not required to submit comparison photographs during their first year of competition.

All teams are reminded to take and retain a set of photographs of their current car to document and support their future entries.

2.2.5.1 Documentation Photograph Format

The documentation photographs should each be approximately 3" x 5" (7.5 cm x 12.5 cm) and printed landscape, four (4) on each 8 ½" x 11" or A4 sheet, with the previous entry on the left and the current entry on the right.



All pages of photographs must be identified by (1) year, (2) university name and (3) vehicle number.

Note: Examples of documentary photograph pairs in the desired format are posted on the FSAE website for your reference.

2.2.6 Withdrawals

Registered teams that find that they will not be able to attend the competition are requested to officially withdraw by notifying the following not later than one (1) week before the event:

Formula SAE North American Event withdrawals: Kaley (Shellhammer) Zundel, shellham@sae.org

For events outside North America, please visit the respective competition website for contact information.

2.2.7 United States Visas

Teams requiring visas to enter to the United States are advised to apply at least sixty (60) days prior to the competition. Although most visa applications seem to go through without an unreasonable delay, occasionally teams have had difficulties and in several instances visas were not issued before the competition.

Don't wait – apply early for your visa.

Neither SAE staff nor any competition organizers are permitted to give advice on either visa or customs matters concerning the United States or any other country.



3. VEHICLE REQUIREMENTS & RESTRICTIONS

The following requirements and restrictions will be enforced through technical inspection. Noncompliance must be corrected and the car re-inspected before the car is allowed to operate under power.

3.1 General Design Requirements

3.1.1 Body and Styling

The vehicle must be open-wheeled and open-cockpit (a formula style body). There must be no openings through the bodywork into the driver compartment from the front of the vehicle back to the roll bar main hoop or firewall other than that required for the cockpit opening. Minimal openings around the front suspension components are allowed.

3.1.2 Wheelbase and Vehicle Configuration

The car must have a wheelbase of at least 1525 mm (60 inches). The wheelbase is measured from the center of ground contact of the front and rear tires with the wheels pointed straight ahead. The vehicle must have four (4) wheels that are not in a straight line.

3.1.3 Vehicle Track

The smaller track of the vehicle (front or rear) must be no less than 75% of the larger track.

3.1.4 Visible Access

All items on the Inspection Form must be clearly visible to the technical inspectors. Visible access can be provided by removing body panels or by providing removable access panels.

3.2 Chassis Rules

3.2.1 Suspension

The car must be equipped with a fully operational suspension system with shock absorbers, front and rear, with usable wheel travel of at least 50.8 mm (2 inches), 25.4 mm (1 inch) jounce and 25.4 mm (1 inch) rebound, with driver seated. The judges reserve the right to disqualify cars which do not represent a serious attempt at an operational suspension system or which demonstrate handling inappropriate for an autocross circuit.

All suspension mounting points must be visible at Technical Inspection, either by direct view or by removing any covers.

3.2.2 Ground Clearance

The ground clearance must be sufficient to prevent any portion of the car (other than tires) from touching the ground during track events, and with the driver aboard there must be a minimum of 25.4 mm (1 inch) of static ground clearance under the complete car at all times.

3.2.3 Wheels and Tires

3.2.3.1 Wheels

The wheels of the car must be 203.2 mm (8.0 inches) or more in diameter.

Any wheel mounting system that uses a single retaining nut must incorporate a device to retain the nut and the wheel in the event that the nut loosens.

3.2.3.2 Tires

Vehicles may have two types of tires as follows:

- **Dry Tires** – The tires on the vehicle when it is presented for technical inspection are defined as its “Dry Tires”. The dry tires may be any size or type. They may be slicks or treaded.
- **Rain Tires** – Rain tires may be any size or type of treaded or grooved tire provided:
 - 1) The tread pattern or grooves were molded in by the tire manufacturer, or were cut by the tire manufacturer or his appointed agent. Any grooves that have been cut must have documentary proof that it was done in accordance with these rules.
 - 2) There is a minimum tread depth of 2.4 mms (3/32 inch).

Note: Hand cutting, grooving or modification of the tires by the teams is specifically prohibited.

Within each tire set, the tire compound or size, or wheel type or size may not be changed after static judging has begun. Tire warmers are not allowed. No traction enhancers may be applied to the tires after the static judging has begun.

3.2.4 Steering

The steering system must affect at least two (2) wheels.

The steering system must have positive steering stops that prevent the steering linkages from locking up (the inversion of a four-bar linkage at one of the pivots). The stops may be placed on the uprights or on the rack and must prevent the tires from contacting suspension, body, or frame members during the track events.

Allowable steering system free play is limited to 7 degrees total measured at the steering wheel.



Rear wheel steering is permitted only if mechanical stops limit the turn angle of the rear wheels to ± 3 degrees from the straight ahead position.

The steering wheel must be mechanically connected to the front wheels, i.e. “steer-by-wire” of the front wheels is prohibited.

3.2.5 Brake Systems

The car must be equipped with a braking system that acts on all four wheels and is operated by a single control. It must have two independent hydraulic circuits such that in the case of a leak or failure at any point in the system, effective braking power is maintained on at least two wheels. Each hydraulic circuit must have its own fluid reserve, either by the use of separate reservoirs or by the use of a dammed, OEM-style reservoir.

A single brake acting on a limited-slip differential is acceptable.

The brake system must be capable of locking all four (4) wheels during the test specified below.

“Brake-by-wire” systems are prohibited.

Unarmored plastic brake lines are prohibited.

The braking systems must be protected with scatter shields from failure of the drive train (see 3.5.1.4) or from minor collisions.

3.2.5.1 Brake Test

The brake system will be dynamically tested and must demonstrate the capability of locking all four (4) wheels and stopping the vehicle in a straight line at the end of an acceleration run specified by the brake inspectors.

3.2.5.2 Brake Over Travel Switch

A brake pedal over-travel switch must be installed on the car. This switch must be installed so that in the event of brake system failure such that the brake pedal over travels, the switch will be activated and will stop the engine from running. This switch must kill the ignition and cut the power to any electrical fuel pumps. Repeated actuation of the switch must not restore power to these components, and it must be designed so that the driver cannot reset it. The switch must be implemented with analog components, and not through recourse to programmable logic controllers, engine control units, or similar functioning digital controllers.

3.2.5.3 Brake Light

The car must be equipped with a red brake light of at least 15 watts, or equivalent, clearly visible from the rear. If an LED brake light is used, it must be clearly visible in very bright sunlight. This light must be mounted between the wheel centerline

and driver's shoulder level vertically and approximately on vehicle centerline laterally.

3.2.6 Jacking Points

A jacking point, which is capable of supporting the car's weight and of engaging the organizers' "quick jacks", must be provided at the rear of the car.

The jacking point is required to be:

- Oriented horizontally and perpendicular to the centerline of the car
- Made from round, 25 – 29 mm (1 – 1 1/8 inch) O.D. aluminum or steel tube
- A minimum of 300 mm (12 inches) long
- Exposed around the lower 180 degrees of its circumference over a minimum length of 280 mm (11 in)

The height of the tube is required to be such that:

- There is a minimum of 75 mm (3 in) clearance from the bottom of the tube to the ground measured at tech inspection.
- With the bottom of the tube 200 mm (7.9 in) above ground, the wheels do not touch the ground when they are in full rebound.

3.3 Structural Requirements

Among other requirements, the vehicle's structure must include two roll hoops that are braced, a front bulkhead with support system and Impact Attenuator, and side impact structures.

3.3.1 Definitions

The following definitions apply throughout the Rules document:

Main Hoop - A roll bar located alongside or just behind the driver's torso.

Front Hoop - A roll bar located above the driver's legs, in proximity to the steering wheel.

Roll Hoops – Both the Front Hoop and the Main Hoop are classified as "Roll Hoops"

Frame Member - A minimum representative single piece of uncut, continuous tubing.

Frame - The "Frame" is the fabricated structural assembly that supports all functional vehicle systems. This assembly may be a single welded structure, multiple welded structures or a combination of composite and welded structures.

Primary Structure – The Primary Structure is comprised of the following Frame components: 1) Main Hoop, 2) Front Hoop, 3) Roll Hoop Braces, 4) Side Impact



Structure, 5) Front Bulkhead, 6) Front Bulkhead Support System and 7) all Frame Members, guides and supports that transfer load from the Driver's Restraint System into items 1 through 6.

Major Structure of the Frame – The portion of the Frame that lies within the envelope defined by the Primary Structure. The upper portion of the Main Hoop and the Main Hoop braces are not included in defining this envelope.

Front Bulkhead – A planar structure that defines the forward plane of the Major Structure of the Frame and functions to provide protection for the driver's feet.

Impact Attenuator – A deformable, energy absorbing device located forward of the Front Bulkhead.

3.3.2 Structural Equivalency and Structural Equivalency Form (SEF)

The use of alternative materials or tubing sizes to those specified in Section 3.3.3.1 "Baseline Steel Material," is allowed, provided they have been judged by a technical review to have equal or superior properties to those specified in Section 3.3.3.1.

Approval of alternative material or tubing sizes will be based upon the engineering judgment and experience of the chief technical inspector or his appointee.

The technical review is initiated by completing the "Structural Equivalency Form" (SEF) using the format given in Appendix A-1.

3.3.2.1 Structural Equivalency Form – Submission

- a) Address – SEF's must be submitted to the officials at the competition you are entering at the address shown in the Appendix or indicated at the competition website.
- b) Due Date – SEF's must be submitted no later than the date given in the "Action Deadlines" in the appendix or the date indicated on the competition website.
- c) Acknowledgement – North America competitions – SEF's submitted for vehicles entered into competitions held in North America will be acknowledged upon receipt.

Do Not Resubmit SEF's

3.3.3 Minimum Material Requirements

3.3.3.1 Baseline Steel Material

The Primary Structure of the car must be constructed of:

Either: Round, mild or alloy, steel tubing (minimum 0.1% carbon) of the minimum dimensions specified in the following table,

Or: Approved alternatives per Section 3.3.3.2

ITEM or APPLICATION	OUTSIDE DIAMETER x WALL THICKNESS
Main & Front Hoops, Shoulder Harness Mounting Bar	1.0 inch (25.4 mm) x 0.095 inch (2.4 mm) or 25.0 mm x 2.50 mm metric
Side Impact Structure, Front Bulkhead, Roll Hoop Bracing, Driver's Restraint Harness Attachment (except as noted above)	1.0 inch (25.4 mm) x 0.065 inch (1.65 mm) or 25.0 mm x 1.75 mm metric or 25.4 mm x 1.60 mm metric
Front Bulkhead Support	1.0 inch (25.4 mm) x 0.049 inch (1.25 mm) or 25.0 mm x 1.5 mm metric or 26.0 mm x 1.2 mm metric

Note 1: The use of alloy steel does not allow the wall thickness to be thinner than that used for mild steel.

Note 2: For a specific application, tubing of the specified outside diameter but with greater wall thickness, OR of the specified wall thickness and a greater outside diameter to those listed above DOES NOT require an SEF submission.

3.3.3.2 Alternative Tubing and Material

3.3.3.2.1 General

Alternative tubing geometry and/or materials may be used except that the Main Roll Hoop and Main Roll Hoop Bracing must be made from steel, i.e. the use of aluminum or titanium tubing or composites is prohibited for these components.

If a team chooses to use alternative tubing and/or materials they must submit a "Structural Equivalency Form" per Section 3.3.2. The teams must submit calculations for the material they have chosen, demonstrating equivalence to the minimum requirements found in Section 3.3.3.1 for yield and ultimate strengths in bending, buckling and tension, for buckling modulus and for energy dissipation. (The Buckling Modulus is defined as EI , where, E = modulus of Elasticity, and I = area moment of inertia about the weakest axis.)

Tubing cannot be of thinner wall thickness than listed in 3.3.3.2.2 or 3.3.3.2.3.

3.3.3.2.2 Steel Tubing Requirements

Minimum Wall Thickness Allowed:

MATERIAL & APPLICATION	MINIMUM WALL THICKNESS
Steel Tubing for Front and Main Roll Hoops	2.0 mm (0.079 inch)
Steel Tubing for Roll Hoop Bracing, Front Bulkhead & Driver's Harness Attachment	1.6 mm (0.063 inch)
Steel Tubing for Side Impact Structure & Front Bulkhead Support	1.2 mm (0.047 inch)

Note 1: All steel is treated equally - there is no allowance for alloy steel tubing, e.g. SAE 4130, to have a thinner wall thickness than that used with mild steel.

Note 2: To maintain EI with a thinner wall thickness than specified in 3.3.3.1, the outside diameter **MUST** be increased.

Note 3: To maintain the equivalent yield and ultimate tensile strength the same cross-sectional area of steel **MUST** be maintained.

3.3.3.2.3 Aluminum Tubing Requirements

Minimum Wall Thickness:

MATERIAL & APPLICATION	MINIMUM WALL THICKNESS
Aluminum Tubing	3.0 mm (0.118 inch)

The equivalent yield strength must be considered in the “as-welded” condition, (Reference: WELDING ALUMINUM (latest Edition) by the Aluminum Association, or THE WELDING HANDBOOK, Vol . 4, 7th Ed., by The American Welding Society), unless the team demonstrates and shows proof that the frame has been properly solution heat treated and artificially aged.

Should aluminum tubing be solution heat-treated and age hardened to increase its strength after welding; the team must supply sufficient documentation as to how the process was performed. This includes, but is not limited to, the heat-treating facility used, the process applied, and the fixturing used.

3.3.3.2.4 Composite Materials

If any composite or other material is used, the team must present documentation of material type, e.g. purchase receipt, shipping document or letter of donation, and of the material properties. Details of the composite lay-up technique as well as the structural material used (cloth type, weight, resin type, number of layers, core material, and skin material if metal) must also be submitted. The team must submit

calculations demonstrating equivalence of their composite structure to one of similar geometry made to the minimum requirements found in Section 3.3.3.1. Equivalency calculations must be submitted for energy dissipation, yield and ultimate strengths in bending, buckling, and tension. Submit the completed “Structural Equivalency Form” per Section 3.3.2.

Composite materials are not allowed for the main hoop or the front hoop.

3.3.4 Roll Hoops

The driver’s head and hands must not contact the ground in any rollover attitude. The Frame must include both a Main Hoop and a Front Hoop as shown in Figure 1.

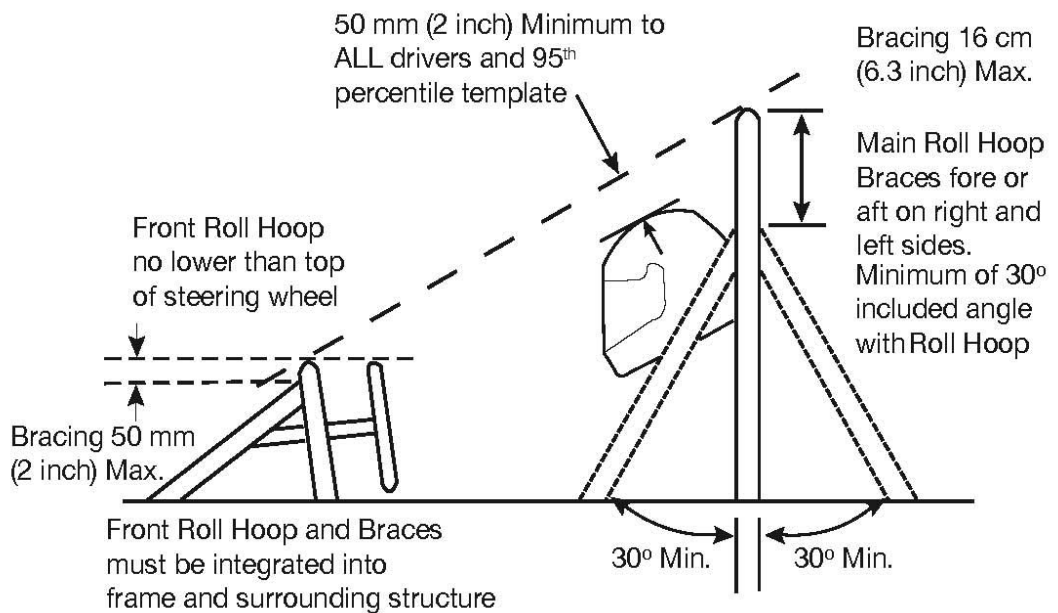

FIGURE 1

3.3.4.1 Main and Front Hoops – General Requirements

When seated normally and restrained by the Driver's Restraint System, a straight line drawn from the top of the main hoop to the top of the front hoop must clear by 50.8 mm (2 inches) the helmet of all the team's drivers and the helmet of a 95th percentile male (anthropometrical data).

95th Percentile Male Template Dimensions

A two dimensional template used to represent the 95th percentile male is made to the following dimensions:

A circle of diameter 200 mm (7.87 inch) will represent the hips and buttocks.

A circle of diameter 200 mm (7.87 inch) will represent the shoulder/cervical region.

A circle of diameter 300 mm (11.81 inch) will represent the head (with helmet).

A straight line measuring 490 mm (19.29 inch) will connect the centers of the two 200 mm circles.

A straight line measuring 280 mm (11.02 inch) will connect the centers of the upper 200 mm circle and the 300 mm head circle.

The 95th percentile male template will be positioned as follows: the seat will be adjusted to the rearmost position, the bottom 200 mm circle will be placed in the seat, and the middle 200 mm circle, representing the shoulders, will be positioned on the seat back. The upper 300 mm circle will be positioned up to 25.4 mm (1 inch) away from the head restraint (i.e. where the driver's helmet would normally be located while driving).

The minimum radius of any bend, measured at the tube centerline, must be at least three times the tube outside diameter. Bends must be smooth and continuous with no evidence of crimping or wall failure.

The Main Hoop and Front Hoop must be securely integrated into the Primary Structure using gussets and/or tube triangulation.

3.3.4.2 Main Hoop

The Main Hoop must be constructed of a single piece of uncut, continuous, closed section steel tubing per Section 3.3.3.

The use of aluminum alloys, titanium alloys or composite materials for the Main Hoop is prohibited.

The Main Hoop must extend from the lowest Frame Member on one side of the Frame, up, over and down the lowest Frame Member on the other side of the Frame.

In the side view of the vehicle, the portion of the Main Roll Hoop that lies above its attachment point to the Major Structure of the Frame must be within 10 (10°) degrees of the vertical.

In the front view of the vehicle, the vertical members of the Main Hoop must be at least 380 mm (15 inch) apart (inside dimension) at the location where the Main Hoop is attached to the Major Structure of the Frame.

On vehicles where the Primary Structure is not made from steel tubes, the Main Hoop must be continuous and extend down to the bottom of the Frame. The Main Hoop must be securely attached to the monocoque structure using 8 mm Grade 8.8 (5/16 in Grade 5) bolts. Mounting plates welded to the Roll Hoop shall be at least 2.0 mm (0.080 inch) thick steel. Steel backup plates of equal thickness must be installed on the opposing side of the monocoque structure such that there is no evidence of crushing of the core. The attachment of the Main Hoop to the monocoque structure requires an approved Structural Equivalency Form per Section 3.3.2. The form must demonstrate that the design is equivalent to a welded Frame and must include justification for the number and placement of the bolts.

3.3.4.3 Front Hoop

The Front Hoop must be constructed of closed section metal tubing per Section 3.3.3.

The use of composite materials is prohibited for the Front Hoop.

The Front Hoop must extend from the lowest Frame Member on one side of the Frame, up, over and down to the lowest Frame Member on the other side of the Frame. With proper gusseting and/or triangulation, it is permissible to fabricate the Front Hoop from more than one piece of tubing.

The top-most surface of the Front Hoop must be no lower than the top of the steering wheel in any angular position.

The Front Hoop must be no more than 250 mms (9.8 inches) forward of the steering wheel. This distance shall be measured horizontally, on the vehicle centerline, from the rear surface of the Front Hoop to the forward most surface of the steering wheel rim with the steering in the straight-ahead position.

In side view, no part of the Front Hoop can be inclined at more than twenty degrees (20°) from the vertical.

3.3.5 Roll Hoop Bracing

3.3.5.1 Main Hoop Bracing

Main Hoop braces must be constructed of closed section steel tubing per Section 3.3.3.

The use of aluminum alloys, titanium alloys or composite materials for the Main Hoop braces is prohibited.

The Main Hoop must be supported by two braces extending in the forward or rearward direction on both the left and right sides of the Main Hoop. In the side view of the Frame, the Main Hoop and the Main Hoop braces must not lie on the

same side of the vertical line through the top of the Main Hoop, i.e. if the Main Hoop leans forward, the braces must be forward of the Main Hoop, and if the Main Hoop leans rearward, the braces must be rearward of the Main Hoop.

The Main Hoop braces must be attached as near as possible to the top of the Main Hoop but not more than 160 mm (6.3 in) below the top-most surface of the Main Hoop. The included angle formed by the Main Hoop and the Main Hoop braces must be at least thirty degrees (30°).

The Main Hoop braces must be straight, i.e. without any bends.

The attachment of the Main Hoop braces must not compromise the function of the bracing i.e. the attachment method and supporting structure must be capable of transmitting all loads from the Main Hoop into the Major Structure of the Frame without failing. The braces must either transmit this load directly to the Major Structure of the Frame, or through a properly triangulated structure. Bracing loads must not be fed solely into the engine, transmission or differential, i.e. the bracing must terminate at a node where there is a load path through the Primary Structure.

If any item which is outside the envelope of the Primary Structure is attached to the Main Hoop braces, then additional bracing must be added to prevent bending loads in the braces in any rollover attitude.

3.3.5.2 Front Hoop Bracing

Front Hoop braces must be constructed of material per Section 3.3.3.

The Front Hoop must be supported by two braces extending in the forward direction on both the left and right sides of the Front Hoop.

The Front Hoop braces must be constructed such that they protect the driver's legs and should extend to the structure in front of the driver's feet.

The Front Hoop braces must be attached as near as possible to the top of the Front Hoop but not more than 50.8 mm (2 in) below the top-most surface of the Front Hoop.

Monocoque construction used as Front Hoop bracing requires an approved Structural Equivalency Form per Section 3.3.2.

If the Front Hoop leans rearwards by more than 10 degrees (10°) from the vertical, it must be supported by additional bracing to the rear. This bracing must be constructed of material per Section 3.3.3.

3.3.5.3 Other Bracing Requirements

Where the braces are not welded to steel Frame Members, the braces must be securely attached to the Frame using 8 mm Grade 8.8 (5/16 in Grade 5), or stronger, bolts. Mounting plates welded to the Roll Hoop braces must be at least 2.0 mm (0.080 in) thick steel.

Where Main Hoop braces are attached to a monocoque structure, backup plates, equivalent to the mounting plates, must be installed on the opposing side of the

monocoque structure such that there is no evidence of crushing of the core. The attachment of the Main Hoop braces to the monocoque structure requires an approved Structural Equivalency Form per Section 3.3.2. The form must demonstrate that the design is equivalent to a welded frame and must include justification for the number and placement of the bolts.

3.3.5.4 Other Side Tube Requirements

If there is a Roll Hoop brace or other frame tube alongside the driver, at the height of the neck of any of the team's drivers, a metal tube or piece of sheet metal must be firmly attached to the Frame to prevent the drivers' shoulders from passing under the roll hoop brace or frame tube, and his/her neck contacting this brace or tube.

3.3.5.5 Mechanically Attached Roll Hoop Bracing

Roll Hoop bracing may be mechanically attached. Any non-permanent joint at either end must be either a double-lug joint as shown in Figures 2 and 3, or a sleeved butt joint as shown in Figure 4. The threaded fasteners used to secure non-permanent joints are considered critical fasteners and must comply with paragraph 3.7.2.2. No spherical rod ends are allowed.

MECHANICALLY ATTACHED ROLL BAR BRACES ATTACHMENT DETAILS (FIGURES 2, 3 & 4)

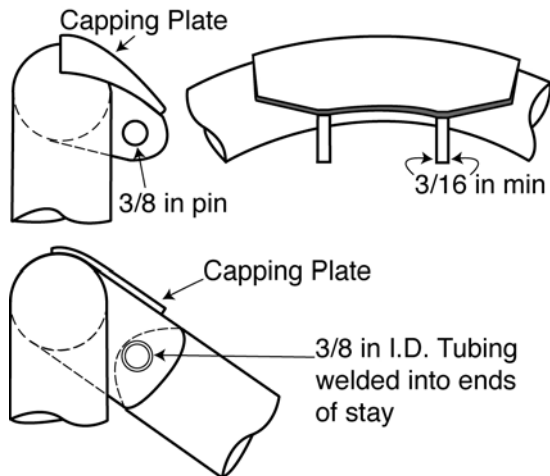

Figure 2

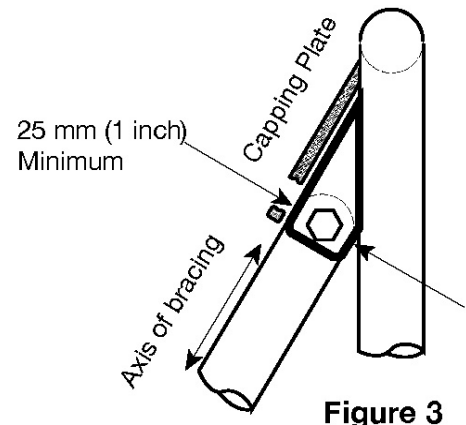

Figure 3

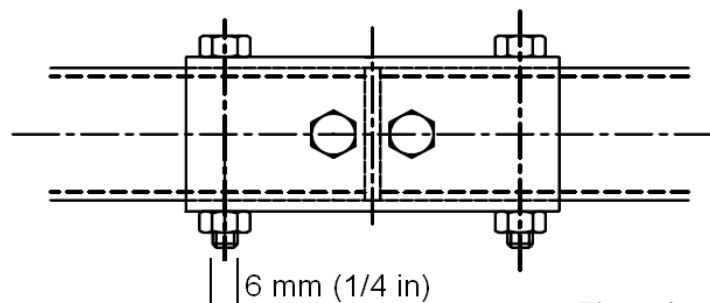

Figure 4

For double-lug joints, each lug must be at least 4.5 mm (0.177 in) thick steel, measure 25 mm (1.0 in) minimum perpendicular to the axis of the bracing and be as short as practical along the axis of the bracing. All double-lug joints, whether fitted at the top or bottom of the tube, must include a capping arrangement (Figures 2 & 3). The pin or bolt must be 10 mm Grade 9.8 (3/8 in. Grade 8) minimum. The attachment holes in the lugs and in the attached bracing must be a close fit with the pin or bolt.

For sleeved butt joints, the sleeve must have a minimum length of 76 mm (3 inch), 38 mm (1.5 inch) either side of the joint, and be a close-fit around the base tubes. The wall thickness of the sleeve must be at least that of the base tubes. The bolts must be 6 mm Grade 9.8 (1/4 inch Grade 8) minimum. The holes in the sleeves and tubes must be a close-fit with the bolts.

3.3.6 Frontal Impact Structure

The driver's feet must be completely contained within the Major Structure of the Frame. While the driver's feet are touching the pedals, in side and front views no part of the driver's feet can extend above or outside of the Major Structure of the Frame.

Forward of the Front Bulkhead must be an energy-absorbing Impact Attenuator.

3.3.6.1 Bulkhead

The Front Bulkhead must be constructed of closed section tubing per Section 3.3.3.

The Front Bulkhead must be located forward of all non-crushable objects, e.g. batteries, master cylinders, hydraulic reservoirs.

The Front Bulkhead must be located such that the soles of the driver's feet, when touching but not applying the pedals, are rearward of the bulkhead plane. (This plane is defined by the forward-most surface of the tubing.) Adjustable pedals must be in the forward most position.

Monocoque construction requires an approved Structural Equivalency Form, per Section 3.3.2. The form must demonstrate that the design is equivalent to a welded Frame in terms of energy dissipation, yield and ultimate strengths in bending, buckling and tension.

3.3.6.2 Front Bulkhead Support

The Front Bulkhead must be securely integrated into the Frame.

The Front Bulkhead must be supported back to the Front Roll Hoop by a minimum of three (3) Frame Members on each side of the vehicle with one at the top (within 50.8 mm (2 inches) of its top-most surface), one (1) at the bottom, and one (1) as a diagonal brace to provide triangulation.

The triangulation must be node-to-node, with triangles being formed by the Front Bulkhead, the diagonal and one of the other two required Front Bulkhead Support Frame Members.

All the Frame Members of the Front Bulkhead Support system listed above must be constructed of closed section tubing per Section 3.3.3.

Monocoque construction requires an approved Structural Equivalency Form, per Section 3.3.2. The form must demonstrate that the design is equivalent to a welded Frame in terms of energy dissipation, yield and ultimate strengths in bending, buckling and tension.

3.3.6.3 Impact Attenuator

The Impact Attenuator must be:

- a. Installed forward of the Front Bulkhead.
- b. At least 200 mm (7.8 in) long, with its length oriented along the fore/aft axis of the Frame.
- c. At least 100 mm (3.9 in) high and 200 mm (7.8 in) wide for a minimum distance of 200 mm (7.8 in) forward of the Front Bulkhead.
- d. Such that it cannot penetrate the Front Bulkhead in the event of an impact. If the Impact Attenuator is foam filled or honeycomb, a 1.5 mm (0.060 in) solid steel or 4.0 mm (0.157 in) solid aluminum metal plate must be integrated into the Impact Attenuator. The metal plate must be the same size as the Front Bulkhead and bolted or welded to the Front Bulkhead.
- e. Attached securely and directly to the Front Bulkhead and not by being part of non-structural bodywork. The attachment of the Impact Attenuator must be constructed to provide an adequate load path for transverse and vertical loads in the event of off-center and off-axis impacts. If not integral with the frame, i.e. welded, a minimum of four (4) 8 mm Grade 8.8 (5/16 inch Grade 5) bolts must attach the Impact Attenuator to the Front Bulkhead.

Alternative designs that do not comply with the minimum specifications given above require an approved “Structural Equivalency Form” per Section 3.3.2.

The attachment of the Impact Attenuator to a monocoque structure requires an approved Structural Equivalency Form per Section 3.3.2.

3.3.6.4 Impact Attenuator Data Requirement

The team must submit calculations and/or test data to show that their Impact Attenuator, when mounted on the front of a vehicle with a total mass of 300 kgs (661 lbs) and run into a solid, non-yielding impact barrier with a velocity of impact of 7.0 metres/second (23.0 ft/sec), would give an average deceleration of the vehicle not to exceed 20 g.

The calculations and/or test data must be submitted electronically in Adobe Acrobat ® format (*.pdf file) to the address and date provided in the Appendix or provided



on the relevant competition website. This material must be a single file (text, drawings, data or whatever you're including). The Impact Attenuator Data must be named as follows: carnumber_schoolname_competition_initial_IAD.pdf using the assigned car number, the complete school name and initials of the competition [Example: 087_University of SAE_FSAEW_IAD.pdf]

The competitions initials for submissions are:

Formula SAE	FSAE
Formula SAE West	FSAEW
Formula SAE at VIR	FSAEV
Formula SAE Australasia	FSAEA
Formula SAE Brasil	FSAEB
Formula SAE Italy	FSAEI
Formula Student	FS

3.3.6.5 Non-Crushable Objects

All non-crushable objects (e.g. batteries, master cylinders, hydraulic reservoirs) must be rearward of the bulkhead. No non-crushable objects are allowed in the impact attenuator zone.

3.3.7 Front Bodywork

Sharp edges on the forward facing bodywork or other protruding components are prohibited. All forward facing edges on the bodywork that could impact people, e.g. the nose, must have forward facing radii of at least 38 mm (1.5 inches). This minimum radius must extend to at least 45 degrees (45°) relative to the forward direction, along the top, sides and bottom of all affected edges.

3.3.8 Side Impact Structure

The Side Impact Structure must meet the requirements listed below.

3.3.8.1 Tube Frames

The Side Impact Structure must be comprised of at least three (3) tubular members located on each side of the driver while seated in the normal driving position, as shown in Figure 5. The three (3) required tubular members must be constructed of material per Section 3.3.3. The locations for the three (3) required tubular members are as follows:

The upper Side Impact Structural member must connect the Main Hoop and the Front Hoop at a height between 300 mm (11.8 inch) and 350 mm (13.8 inch) above the ground with a 77kg (170 pound) driver seated in the normal driving position. The upper frame rail may be used as this member if it meets the height, diameter and thickness requirements.

The lower Side Impact Structural member must connect the bottom of the Main Hoop and the bottom of the Front Hoop. The lower frame rail/frame member may be this member if it meets the diameter and wall thickness requirements.

The diagonal Side Impact Structural member must connect the upper and lower Side Impact Structural members forward of the Main Hoop and rearward of the Front Hoop.

With proper gusseting and/or triangulation, it is permissible to fabricate the Side Impact Structural members from more than one piece of tubing.

Alternative geometry that does not comply with the minimum requirements given above requires an approved “Structural Equivalency Form” per Section 3.3.2.

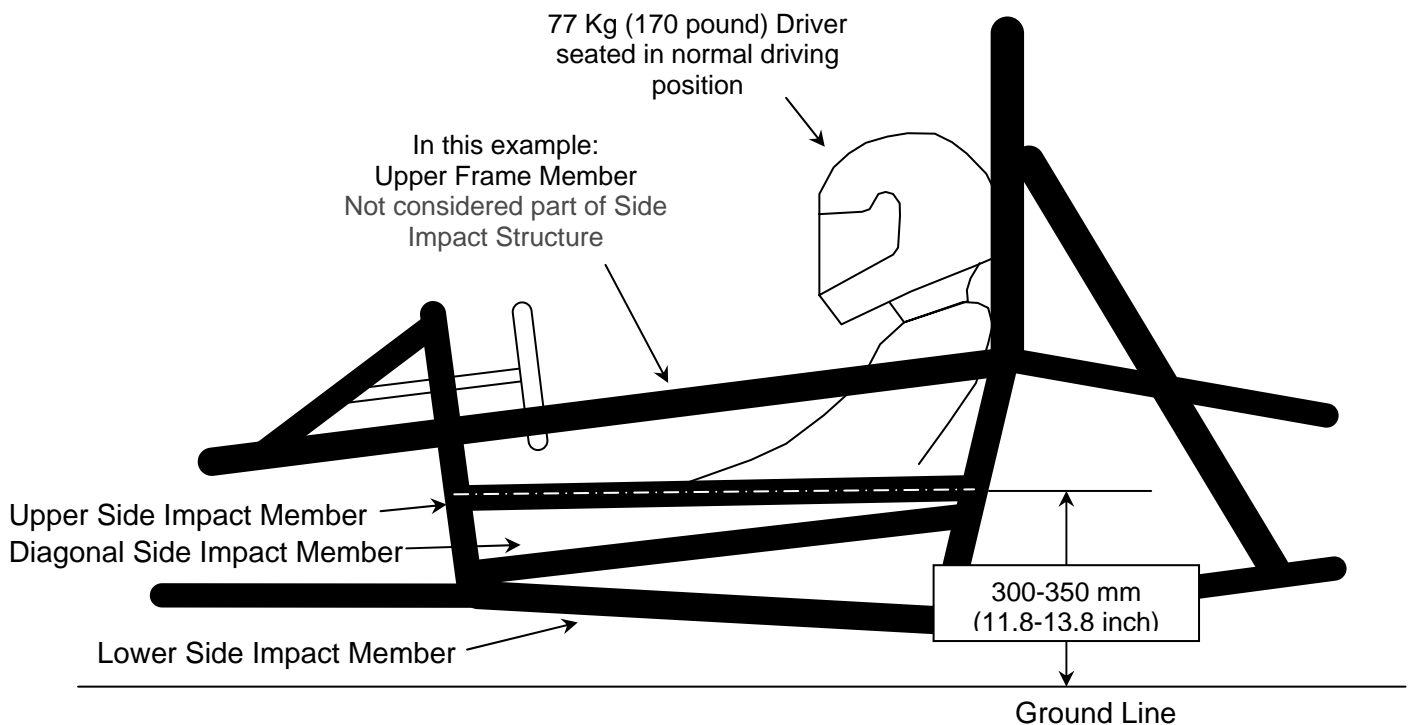

3.3.8.2 Composite Monocoque

The section properties of the sides of the vehicle must reflect impact considerations. Non-structural bodies or skins alone are not adequate. Teams building composite monocoque bodies must submit the “Structural Equivalency Form” per Section 3.3.2. Submitted information should include: material type(s), cloth weights, resin type, fiber orientation, number or layers, core material, and lay-up technique.

3.3.8.3 Metal Monocoque

These structures must meet the same requirements as tube frames and composite monocoque. Teams building metal monocoque bodies must submit the “Structural Equivalency Form” per Section 3.3.2

3.3.9 Inspection Holes

To allow the verification of tubing wall thicknesses, 4.5 mm (0.18 inch) inspection holes must be drilled in a non-critical location of both the Main Hoop and the Front Hoop.

In addition, the Technical Inspectors may check the compliance of other tubes that have minimum dimensions specified in 3.3.3. This may be done by the use of ultrasonic testing or by the drilling of additional inspection holes at the inspector's request.

Inspection holes must be located so that the outside diameter can be measured ACROSS the inspection hole with a vernier caliper, i.e. there must be access for the vernier caliper to the inspection hole and to the outside of the tube one hundred eighty degrees (180°) from the inspection hole.

3.4 Driver and Cockpit Equipment

3.4.1 Driver Restraint System

All drivers must use a 5, 6 or 7 point restraint harness meeting the following specifications. The restraint system installation is subject to approval of the Chief Technical Inspector. The restraint system must be worn as tightly as possible at all times.

(A) Material Requirements

The material of all straps must be Nylon or Dacron polyester and in new or perfect condition. There must be a single release common to the lap belt and shoulder harness using a metal-to-metal quick-release type latch. All driver restraint systems must meet either SFI Specification 16.1, or FIA specification 8853/98. The belts must bear the appropriate dated labels.

(B) Harness Replacement

SFI spec harnesses must be replaced following December 31st of the 2nd year after the date of manufacture as indicated by the label.

FIA spec harnesses must be replaced following December 31st of the year marked on the label. (Note: FIA belts are normally certified for five (5) years from the date of manufacture.)

(C) 5-Point System

A 5-point system consists of a 76 mm (3 inch) wide lap belt, approximately 76 mm (3 inch) wide shoulder straps and a single approximately 51 mm (2 inch) wide anti-submarine strap. The single anti-submarine strap must have a metal-to-metal connection with the single release common to the lap belt and shoulder harness.

(D) 6 and 7-Point Systems

A 6-point system consists of a 76 mm (3 inch) wide lap belt, approximately 76 mm (3 inch) wide shoulder straps and two approximately 51 mm (2 inch) wide leg or anti-submarine straps. A 7-point system is the same as the 6-point except it has three (3) anti-submarine straps, two (2) from the 6-point system and one (1) from the 5-point system.

6 and 7-point harnesses to FIA specification 8853/98 with approximately 51 mm (2 inch) lap belts are acceptable.

The double leg straps of the 6 or 7-point system may be attached to the Primary Structure, or be attached to the lap belt so that the driver sits on them, passing them up between his or her legs and attaching to the single release common to the lap belt and shoulder harness. The leg straps may also be secured at a point common with the lap belt attachment to Primary Structure, passing them under the driver and up between his or her legs to the harness release.

(E) Belt and Strap Mounting

The lap belt, shoulder harness and anti-submarine strap(s) must be securely mounted to the Primary Structure. Such structure and any guide or support for the belts must meet the minimum requirements of 3.3.3.

The attachment of the Driver's Restraint System to a monocoque structure requires an approved Structural Equivalency Form per Section 3.3.2.

(F) Lap Belt Mounting

The lap belt must pass around the pelvic area below the Anterior Superior Iliac Spines (the hip bones) (Figure 6a). Under no condition may the lap belt be worn over the area of the intestines or abdomen. The lap belts should come through the seat at the bottom of the sides of the seat to maximize the wrap of the pelvic surface and continue in a straight line to the anchorage point.

In side view, the lap belt must be at an angle of between 45 degrees (45°) and 65 degrees (65°) to the horizontal. This means that the centerline of the lap belt at the seat bottom should be between 0 - 76 mm (0 - 3 inch) forward of the seat back to seat bottom junction (see Figure 6).

To fit drivers of differing statures correctly, in side view, the lap belt must be capable of pivoting freely by using either a shouldered bolt or an eye bolt attachment, i.e. mounting lap belts by wrapping them around frame tubes is no longer acceptable.

The lap belts should not be routed over the sides of the seat. The seat must be rolled or grommeted to prevent chafing of the belts.

(G) Shoulder Harness

The shoulder harness must be the over-the-shoulder type. Only separate shoulder straps are permitted (i.e. “Y”-type shoulder straps are not allowed). The “H”-type configuration is allowed.

It is mandatory that the shoulder harness, where it passes over the shoulders, be 76 mm (3 inch) wide, except as noted below. The shoulder harness straps must be threaded through the three bar adjusters in accordance with manufacturers instructions.

When the HANS device is used by the driver, FIA certified 51 mm (2 inch) wide shoulder harnesses are allowed. Should a driver, at anytime not utilize the HANS device, then 76 mm (3 inch) wide shoulder harnesses are required.

The shoulder harness must be mounted behind the driver to structure that meets the requirements of 3.3.3. However, it cannot be mounted to the Main Roll Hoop Bracing or attendant structure without additional bracing to prevent loads being transferred into the Main Hoop Bracing.

The shoulder harness mounting points must be between 178 mm (7 inches) and 229 mm (9 inches) apart.

From the driver’s shoulders rearwards to the mounting point or structural guide, the shoulder harness must be between 10 degrees (10°) above the horizontal and 20 degrees (20°) below the horizontal.

FIGURE 6 a
Lap Belt Angle

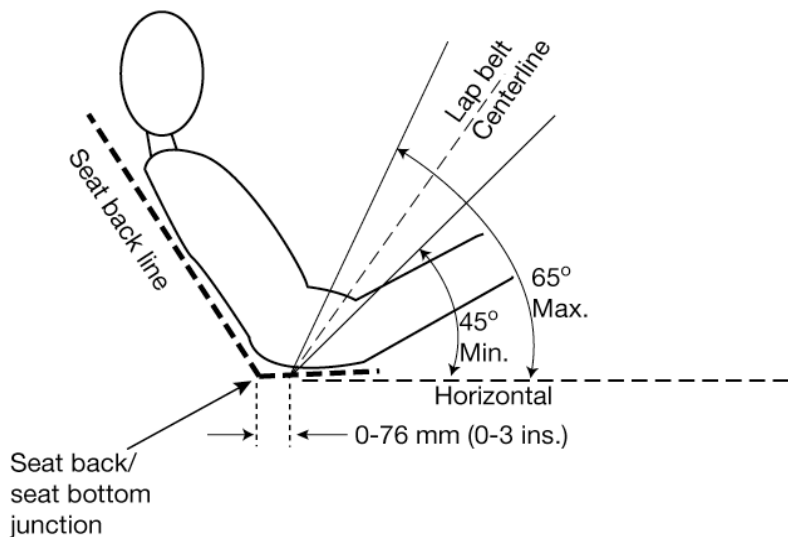

FIGURE 6 b

Shoulder Harness Angle

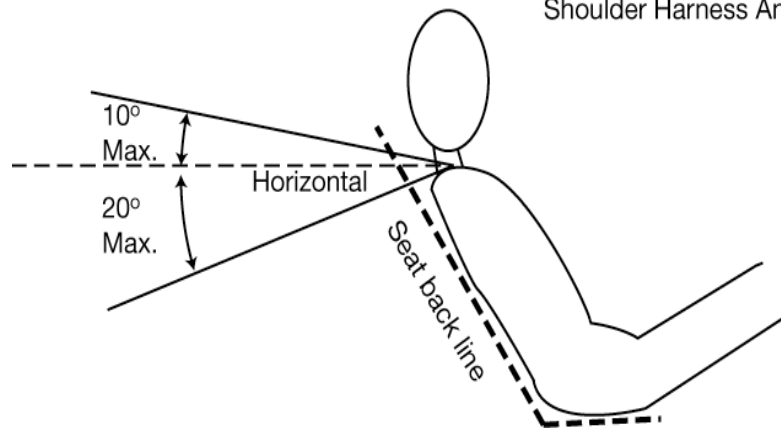
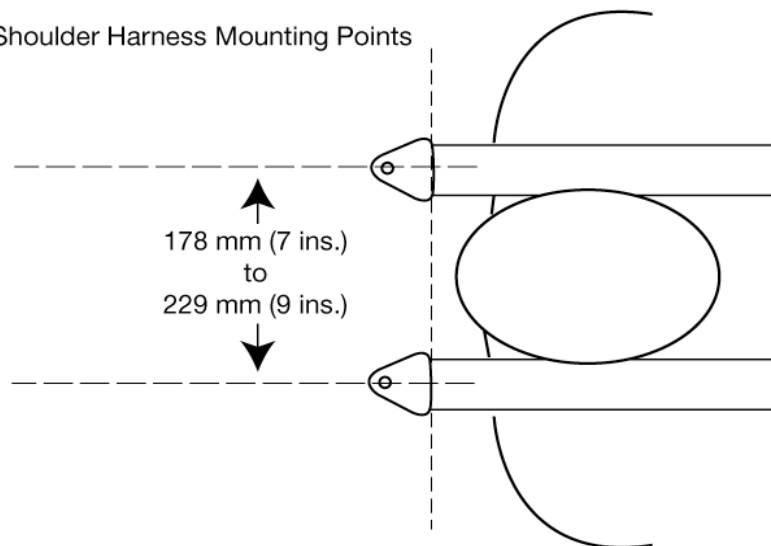

FIGURE 6 c

Shoulder Harness Mounting Points



3.4.2 Driver's Equipment

The following equipment must be worn by the driver anytime he or she is in the cockpit with the engine running.

There must be no bare skin below the driver's neck level when seated in the vehicle.

3.4.2.1 Helmet

A well-fitting, closed face helmet that meets one of the following certifications and is labeled as such:

- Snell M2000, SA2000, M2005, K2005, SA2005
- SFI 31.2A, SFI 31.1/2005
- FIA 8860-2204

- British Standards Institution BS 6658-85 types A or A/FR rating (Type B is not accepted)

Open faced helmets are not approved.

All helmets to be used in the competition must be presented during Technical Inspection where approved helmets will be stickered. The organizer reserves the right to impound all non-approved helmets until the end of the competition.

3.4.2.2 Suit

A fire resistant suit that covers the body from the neck down to the ankles and the wrists. The suit must be in good condition, i.e. it must have no tears or open seams, or oil stains that could compromise its fire resistant capability. The suit must be certified to one of the following standards and be labeled as such:

- SFI 3-2A/1 (or higher)

Figure A



- FIA Standard 8856-1986

Figure B

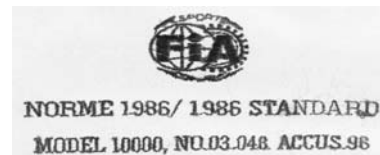

- FIA Standard 8856-2000

Figure C

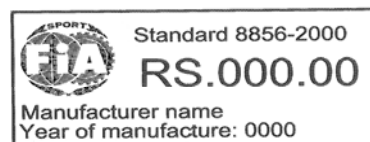

Actual size 100x40mm

3.4.2.3 Gloves

Fire resistant gloves which are free of any holes. Leather gloves are not acceptable.

3.4.2.4 Goggles or Face Shields

Goggles or face shields, made of impact resistant materials.

3.4.2.5 Shoes

Shoes of durable fire resistant material and which are free from any holes.

3.4.2.6 Arm Restraints

Arm restraints must be worn such that the driver can release them and exit the vehicle unassisted regardless of the vehicle's position.



3.4.2.7 Hair Covering

Beards, mustaches, and hair protruding from beneath a driver's helmet must be completely covered by fire resistant material, e.g. a Nomex balaclava or a full helmet skirt of accepted fire resistant material.

3.4.3 Driver Visibility

3.4.3.1 General Requirement

The driver must have adequate visibility to the front and sides of the car. With the driver seated in a normal driving position he/she must have a minimum field of vision of 200 degrees (200°) (a minimum 100 (100°) degrees to either side of the driver). The required visibility may be obtained by the driver turning his/her head and/or the use of mirrors.

3.4.3.2 Mirrors

If mirrors are required to meet Rule 3.4.3.1, they must remain in place and adjusted to enable the required visibility throughout all dynamic events.

3.4.4 Head Restraint and Roll bar Padding

A head restraint must be provided on the car to limit the rearward motion of the driver's head. The restraint must have a minimum area of 232 sq. cm (36 sq. inches), be padded with an energy absorbing material such as Ethafoam® or Ensolite® with a minimum thickness of 38 mm (1.5 inches), and be located no more than 25 mm (1 inch) away from the helmet in the uncompressed state. The head restraint must meet the above requirements for all drivers. The restraint, its attachment and mounting must be strong enough to withstand a force of 890 Newtons (200 lbs. force) applied in a rearward direction.

Any portion of the roll bar, roll bar bracing or frame which might be contacted by the driver's helmet must be covered by an energy-absorbing material such as Ethafoam® or Ensolite® or other similar material, to a minimum thickness of 12 mm (0.5 inch). Pipe insulation material is unacceptable for this application.

3.4.5 Floor Closeout

All vehicles must have a floor closeout made of one or more panels, which separate the driver from the pavement. If multiple panels are used, gaps between panels are not to exceed 3 mm (1/8 inch). The closeout must extend from the foot area to the firewall and prevent track debris from entering the car. The panels must be made of a solid, non-brittle material.



3.4.6 Steering Wheel

3.4.6.1 Circular Shape

The steering wheel must have a continuous perimeter that is near circular or near oval. “H”, “Figure 8”, or cutout wheels are not allowed.

3.4.6.2 Quick Disconnect

The steering wheel must be attached to the column with a quick disconnect. The driver must be able to operate the quick disconnect while in the normal driving position with gloves on.

3.4.7 Driver Egress

All drivers must be able to exit to the side of the vehicle in no more than 5 seconds.

Egress time begins with the driver in the fully seated position, hands in driving position on the connected steering wheel, wearing the required driver equipment. Egress time will stop when the driver has both feet on the pavement.

3.4.8 Roll Over Stability

The track and center of gravity of the car must combine to provide adequate rollover stability.

3.4.8.1 Tilt Table

Rollover stability will be evaluated using a pass/fail test. The vehicle must not roll when tilted at an angle of 60 degrees (60°) to the horizontal in either direction, corresponding to 1.7 G's. The tilt test will be conducted with the tallest driver in the normal driving position.

3.4.9 Master Switches

The vehicle must be equipped with two (2) master switches. Actuating either switch must stop the engine.

The international electrical symbol consisting of a red spark on a white-edged blue triangle must be affixed in close proximity to each switch.

Note: Teams are reminded that any alternator field wire must also be disabled by each master switch to prevent any possible feedback through the field coil circuit.

3.4.9.1 Primary Master Switch

The primary master switch must:

- A. Be located on the (driver's) right side of the vehicle, in proximity to the Main Hoop, at shoulder height and be easily actuated from outside the car.

- B. Disable power to ALL electrical circuits, including the battery, alternator, lights, fuel pump(s), ignition and electrical controls. All battery current must flow through this switch.
- C. Be of a rotary type and must be direct acting, i.e. it cannot act through a relay. An example of a typical switch that meets these requirements is shown in Figure D.

The “OFF” position of the primary master switch must be clearly marked.



Figure D

3.4.9.2 Cockpit-mounted Master Switch

The cockpit-mounted master switch:

- A. Must be located to provide easy actuation by the driver in an emergency or panic situation. The switch must be located within easy reach of the belted-in driver, alongside the steering wheel, and unobstructed by the steering wheel or any other part of the car. It is suggested that it be placed on the same side of the steering wheel as the shifter mechanism.
- B. Must be a push/pull Emergency switch. The switch must be installed such that: (a) from the ON position, pushing on the switch will disable power to the ignition and all fuel pumps, and (b) from the OFF position, pulling on the switch will enable power to the ignition and fuel pump(s). Switches that require a twist or twist and pull to enable power are acceptable.
- C. May act through a relay.

Examples of typical switches that meet these requirements are shown in Figure E.



Figure E

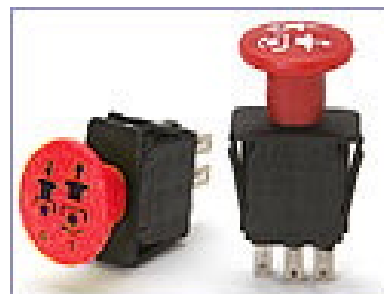

3.4.10 Fire Protection

3.4.10.1 Firewall

A firewall must separate the driver compartment from all components of the fuel supply, the engine oil and the liquid cooling systems. It must protect the neck of the tallest driver. It must extend sufficiently far upwards and/or rearwards such that any point less than 100 mm (4 ins.) above the bottom of the helmet of the tallest driver shall not be in direct line of sight with any part of the fuel system, the cooling system or the engine oil system.

The firewall must be a non-permeable surface made from a fire resistant material. Pass-throughs for wiring, cables, etc. are allowable if grommets are used to seal the pass-throughs. Also, multiple panels may be used to form the firewall but must be sealed at the joints.

3.4.10.2 Fire Extinguishers

Each team must have at least two (2) 0.9 kg (2 lb.) dry chemical/dry powder or 1.75 litres Aqueous Film Forming Foam (AFFF), fire extinguishers.

The following are the minimum ratings, any of which are acceptable at any Formula SAE Series event:

- USA, Canada & Brazil: 10BC or 1A 10BC
- UK, Italy & Europe: 34B or 5A 34B
- Australia: 20BE or 1A 10BE

Extinguishers of larger capacity (higher numerical ratings) are acceptable.

All extinguishers must be equipped with a manufacturer installed pressure/charge gauge.

Except for the initial inspection, one extinguisher must readily be available in the team's paddock area, and the second must accompany the vehicle wherever the vehicle is moved. Both extinguishers must be presented with the vehicle at Technical Inspection.

As a team option, commercially available on-board fire systems are encouraged as an alternative to the extinguisher that accompanies the vehicle.

Hand held fire extinguishers are not permitted to be mounted on or in the car.

Note: Halon extinguishers and systems are no longer acceptable at Formula SAE competitions.

3.4.11 Batteries

All batteries, i.e. on-board power supplies, must be attached securely to the frame. Any wet-cell battery located in the driver compartment must be enclosed in a nonconductive marine-type container or equivalent. The hot terminal must be insulated on all cars.

3.4.12 Accessibility of Controls

All vehicle controls, including the shifter, must be operated from inside the cockpit without any part of the driver, e.g. hands, arms or elbows, being outside the planes of the Side Impact Structure defined in 3.3.8.

3.4.13 Seat

The lowest point of the driver's seat must be no lower than the bottom surface of the lower frame rails or by having a longitudinal tube (or tubes) that meets the requirements for Side Impact tubing, passing underneath the lowest point of the seat.

3.4.14 Driver's Leg Protection

To keep the driver's legs away from moving or sharp components, all moving suspension and steering components, and other sharp edges inside the cockpit between the front roll hoop and a vertical plane 100 mm (4 inches) rearward of the pedals, must be shielded with a shield made of a solid material. Moving components include, but are not limited to springs, shock absorbers, rocker arms, anti-roll/sway bars, steering racks and steering column CV joints.

Covers over suspension and steering components must be removable to allow inspection of the mounting points.

3.5 Powertrain

3.5.1 Engine and Drivetrain

3.5.1.1 Engine Limitations

The engine(s) used to power the car must be four-stroke piston engine(s) with a displacement not exceeding 610 cc per cycle. The engine can be modified within the restrictions of the rules. If more than one engine is used, the total displacement can not exceed 610 cc and the air for all engines must pass through a single air intake restrictor (see 3.5.4.3, "Intake System Restrictor.")

Hybrid powertrains utilizing on-board energy storage are not allowed.

3.5.1.2 Engine Inspection

The organizer will measure or tear down a substantial number of engines to confirm conformance to the rules. The initial measurement will be made externally with a measurement accuracy of one (1) percent. When installed to and coaxially with spark plug hole, the measurement tool has dimensions of 381 mm (15 inches) long and 30 mm (1.2 inches) diameter. Teams may choose to design in access space for this tool above each spark plug hole to reduce time should their vehicle be inspected.

3.5.1.3 Transmission and Drive

Any transmission and drivetrain may be used.

3.5.1.4 Drive Train Shields and Guards

Exposed high-speed equipment, such as torque converters, clutches, belt drives and clutch drives, must be fitted with scatter shields in case of failure. Scatter shields for chains or belts must not be made of perforated material.

- A. Chain drive - Scatter shields for chains must be made of at least 2.66 mm (0.105 inch) steel (no alternatives are allowed), and have a minimum width equal to three (3) times the width of the chain.
- B. Belt drive - Scatter shields for belts must be made from at least 3.0 mm (0.120 inch) Aluminum Alloy 6061-T6, and have a minimum width that is equal to the belt width plus 35% on each side of the belt (1.7 times the width of the belt).
- C. Attachment Fasteners - All fasteners attaching scatter shields and guards must be a minimum 6mm grade M8.8 (1/4 inch SAE grade 5).
- D. Attached shields and guards must be mounted so that they remain laterally aligned with the chain or belt under all conditions.
- E. Finger Guards – Finger guards may be made of lighter material.

3.5.1.5 System Sealing

The engine and transmission must be sealed to prevent leakage.

Separate catch cans must be employed to retain fluids from any vents for the coolant system or the crankcase or engine lubrication system. Each catch-can must have a minimum volume of ten (10) percent of the fluid being contained or 0.9 liter (one U.S. quart) whichever is greater.

Catch cans must be capable of containing boiling water without deformation, and be located rearwards of the firewall below driver's shoulder level. They must have a vent with a minimum diameter of 3 mm (1/8 inch) with the vent pointing away from the driver.

Any crankcase or engine lubrication vent lines routed to the intake system must be connected upstream of the intake system restrictor.

3.5.1.6 Coolant Fluid Limitations

Water-cooled engines must only use plain water, or water with cooling system rust and corrosion inhibitor at no more than 0.015 liters per liter of plain water. Glycol-based antifreeze or water pump lubricants of any kind are strictly prohibited.

3.5.1.7 Starter

Each car must be equipped with an on-board starter, and be able to start without any outside assistance at any time during the competition.



3.5.2 Fuels

The basic fuel available at competitions in the Formula SAE Series is unleaded gasoline with an octane rating of 93 (R+M)/2 (approximately 98 RON). Other fuels may be available at the discretion of the organizing body.

Unless otherwise announced by the individual organizing body, the fuel at competitions in the Formula SAE Series will be provided by the organizer.

During all performance events the cars must be operated with the fuels provided by the organizer at the competition.

Nothing may be added to the provided fuels. This prohibition includes nitrous oxide or any other oxidizing agent.

Teams are advised that the fuel supplied in the United States is subject to various federal and state regulations and may contain up to ten percent (10%) ethanol. The exact chemical composition and physical characteristics of the available fuel may not be known prior to the competition.

Consult the individual competition websites for fuel types and other information.

3.5.2.1 Fuel Temperature Changes – Prohibited

The temperature of fuel introduced into the fuel system may not be changed with the intent to improve calculated fuel economy.

3.5.2.2 Fuel Additives – Prohibited

No agents other than fuel (gasoline or E85), and air may be induced into the combustion chamber. Non-adherence to this rule will be reason for disqualification. Officials have the right to inspect the oil.

3.5.3 Fuel System

3.5.3.1 Fuel Tank Size Limit

Any size fuel tank may be used.

The fuel system must have a provision for emptying the fuel tank if required.

3.5.3.2 Filler Neck & Sight Tube

All fuel tanks must have a filler neck: (a) at least 38 mm (1.5 inches) diameter, (b) at least 125 mm (4.9 inches) vertical height and (c) angled at no more than 45 degrees (45°) from the vertical. The 125 mm of vertical height must be above the top level of the tank, and must be accompanied by a clear fuel resistant sight tube for reading fuel level (figure 7). The sight tube must have at least 75 mm (3 inches) of vertical height and a minimum inside diameter of 6 mm (0.25 inches). The sight tube must not run below the top surface of the fuel tank. A clear filler tube may be

used, subject to approval by the Rules Committee or technical inspectors at the event.

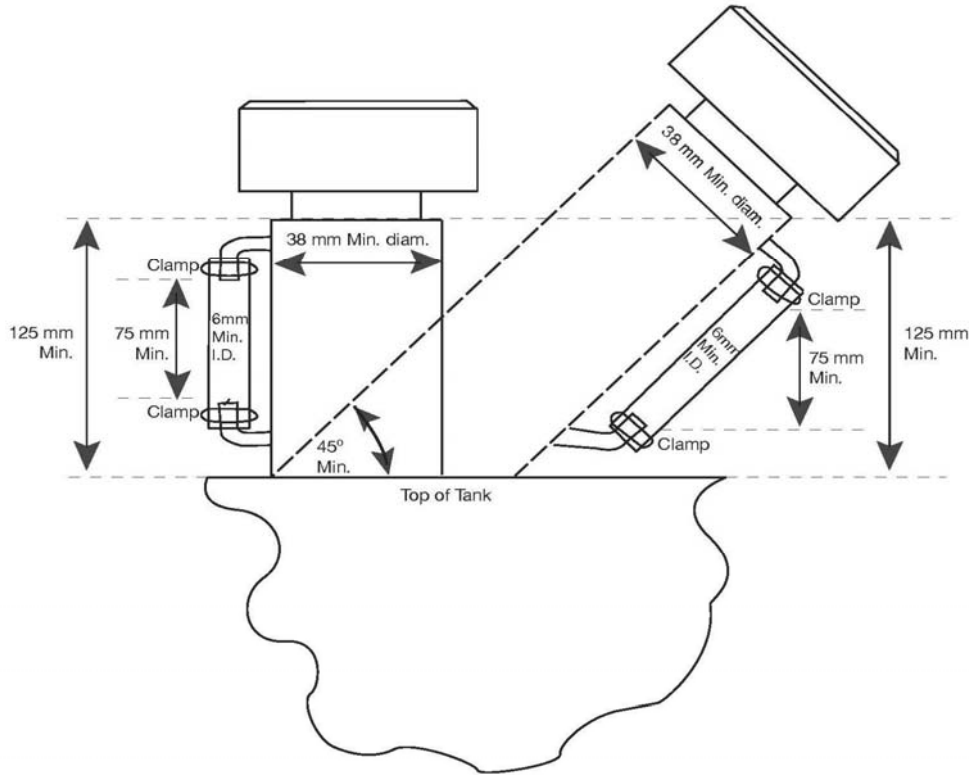

FIGURE 7

3.5.3.3 Fuel Level Line

A permanent, non-moveable fuel level line must be located between 12.7 mm and 25.4 mm (0.5 inch and 1 inch) below the top of the sight tube. This line will be used as the fill line for Tilt Test (3.5.3.6 and 4.2.3), and before and after the Endurance Test to measure the amount of fuel used during the Endurance Event.

The sight tube and fuel level line must be clearly visible to an individual filling the tank.

3.5.3.4 Tank Filling Requirement

The tank must be capable of being filled to capacity without manipulating the tank or vehicle in any way (shaking vehicle, etc.).

3.5.3.5 Spillage Prevention

The fuel system must be designed such that the spillage during refueling cannot contact the driver position, exhaust system, hot engine parts, or the ignition system. Belly pans must be vented to prevent accumulation of fuel.

3.5.3.6 Venting Systems

The fuel tank and carburetor venting systems must be designed such that fuel cannot spill during hard cornering or acceleration. This is a concern since motorcycle carburetors normally are not designed for lateral accelerations.

All fuel vent lines must be equipped with a check valve to prevent fuel leakage when the tank is inverted. All fuel vent lines must exit outside the bodywork.

3.5.3.6.1 Tilt Test-Fuel and Fluids

During technical inspection, the car must be capable of being tilted to a 45 degree (45°) angle without leaking fuel or fluid of any type.

The tilt test will be conducted with the vehicle containing the maximum amount of fluids it will carry during any test or event.

3.5.3.7 Fuel Lines, Line Attachment and Protection

Plastic fuel lines between the fuel tank and the engine (supply and return) are prohibited.

If rubber fuel line or hose is used, the components over which the hose is clamped must have annular bulb or barbed fittings to retain the hose. Also, clamps specifically designed for fuel lines must be used. These clamps have three (3) important features, (i) a full 360 degree (360°) wrap, (ii) a nut and bolt system for tightening, and (iii) rolled edges to prevent the clamp cutting into the hose. Worm-gear type hose clamps are not approved for use on any fuel line.

Fuel lines must be securely attached to the vehicle and/or engine. All fuel lines must be shielded from possible rotating equipment failure or collision damage.

3.5.3.8 Fuel Injection System Requirement

The following requirements apply to fuel injection systems.

- A. Fuel Lines – Flexible fuel lines must be either (i) metal braided hose with either crimped-on or reusable, threaded fittings, or (ii) reinforced rubber hose with some form of abrasion resistant protection with fuel line clamps per 3.5.3.7. Note: Hose clamps over metal braided hose will not be accepted.
- B. Fuel Rail – The fuel rail must be securely attached to the engine cylinder block, cylinder head, or intake manifold with brackets and mechanical fasteners. This precludes the use of hose clamps, plastic ties, or safety wire.
- C. Intake Manifold – The intake manifold must be securely attached to the engine block or cylinder head with brackets and mechanical fasteners. This precludes the use of hose clamps, plastic ties, or safety wires. The use of rubber bushings or hose is acceptable for creating and sealing air passages, but is not considered a structural attachment.

3.5.3.9 Air Intake and Fuel System Location Requirements

All parts of the fuel storage and supply system, and all parts of the engine air and fuel control systems (including the throttle or carburetor, and the complete air intake system, including the air cleaner and any air boxes) must lie within the surface defined by the top of the roll bar and the outside edge of the four tires (see figure 8).

All fuel tanks must be shielded from side impact collisions. Any fuel tank which is located outside the Side Impact Structure required by 3.3.8, must be shielded by structure built to 3.3.8. A firewall must also be incorporated, per section 3.4.10.1.

Any portion of the air intake system that is less than 350 mm (13.8 inches) above the ground must be shielded by structure built to 3.3.8.

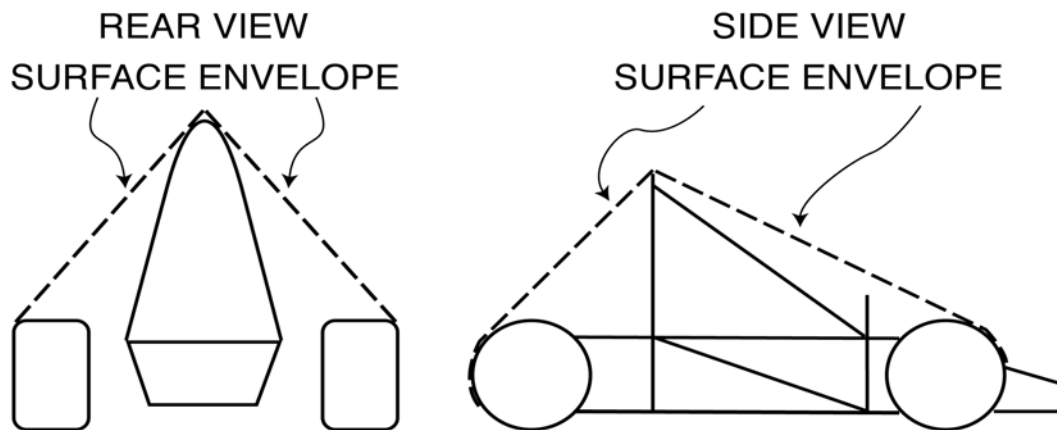

FIGURE 8

3.5.4 Throttle, Throttle Actuation and Intake Restrictor

3.5.4.1 Carburetor/Throttle Body – Required

The car must be equipped with a carburetor or throttle body. The carburetor or throttle body may be of any size or design.

3.5.4.2 Throttle Actuation

The throttle must be actuated mechanically, i.e. via a cable or a rod system. The use of electronic throttle control (ETC) or “drive-by-wire” is prohibited.

The throttle cable or rod must have smooth operation, and must not have the possibility of binding or sticking.

The throttle actuation system must use at least two (2) return springs located at the throttle body, so that the failure of any component of the throttle system will not prevent the throttle returning to the closed position.

Note: Throttle Position Sensors (TPS) are NOT acceptable as return springs.



Throttle cables must be at least 50.8 mm (2 inches) from any exhaust system component and out of the exhaust stream.

A positive pedal stop must be incorporated on the throttle pedal to prevent over stressing the throttle cable or actuation system.

The use of a push-pull type throttle cable with a throttle pedal that is capable of forcing the throttle closed (e.g. toe strap) is recommended.

3.5.4.3 Intake System Restrictor

In order to limit the power capability from the engine, a single circular restrictor must be placed in the intake system between the throttle and the engine and all engine airflow must pass through the restrictor. Any device that has the ability to throttle the engine downstream of the restrictor is prohibited.

The maximum restrictor diameters are:

- Gasoline fueled cars - 20.0 mm (0.7874 inch)
- E-85 fueled cars – 19.0 mm (0.7480 inch)

The restrictor must be located to facilitate measurement during the inspection process. The circular restricting cross section may NOT be movable or flexible in any way, e.g. the restrictor may not be part of the movable portion of a barrel throttle body.

If more than one engine is used, the intake air for all engines must pass through the one restrictor.

3.5.4.4 Turbochargers & Superchargers

Turbochargers or superchargers are allowed if the competition team designs the application. Engines that have been designed for and originally come equipped with a turbocharger are not allowed to compete with the turbo installed.

The restrictor must be placed upstream of the compressor but after the carburetor or throttle valve. Thus, the only sequence allowed is throttle, restrictor, compressor, engine.

The intake air may be cooled with an intercooler (a charge air cooler). Only ambient air may be used to remove heat from the intercooler system. Air-to-air and water-to-air intercoolers are permitted. The coolant of a water-to-air intercooler system must comply with Rule 3.5.1.6.

3.5.5 Muffler and Exhaust System

3.5.5.1 Muffler

The car must be equipped with a muffler in the exhaust system to reduce the noise to an acceptable level.

3.5.5.2 Exhaust Outlet

The exhaust must be routed so that the driver is not subjected to fumes at any speed considering the draft of the car.

The exhaust outlet(s) must not extend more than 60 cm (23.6 inches) behind the centerline of the rear axle, and shall be no more than 60 cm (23.6 inches) above the ground.

Any exhaust components (headers, mufflers, etc.) that protrude from the side of the body in front of the main roll hoop must be shielded to prevent contact by persons approaching the car or a driver exiting the car.

3.5.5.3 Noise

A. Sound Measuring Procedure

The sound level will be measured during a static test. Measurements will be made with a free-field microphone placed free from obstructions at the exhaust outlet level, 0.5 m (19.68 inches) from the end of the exhaust outlet, at an angle of 45 degrees (45°) with the outlet in the horizontal plane. The test will be run with the gearbox in neutral at the engine speed defined below. Where more than one exhaust outlet is present, the test will be repeated for each exhaust and the highest reading will be used.

The car must be compliant at all engine speeds up to the test speed defined below.

B. Test Speeds

The test speed for a given engine will be the engine speed that corresponds to an average piston speed of 914.4 m/min (3,000 ft/min) for automotive or motorcycle engines, and 731.5 m/min (2,400 ft/min) for “industrial engines”. The calculated speed will be rounded to the nearest 500 rpm. The test speeds for typical engines will be published by the organizers. The definition of “an industrial engine” is that used in Rule 4.3.8. To have an engine classified as “an industrial engine”, approval must be obtained from organizers prior to the Competition.

C. Maximum Sound Level

The maximum permitted sound level is 110 dBA, fast weighting.

D. Sound Level Re-testing

At the option of the judges, noise can be measured at any time during the competition. If a car fails the noise test, it will be withheld from the competition until it has been modified and re-passes the noise test.

3.6 Vehicle Identification

3.6.1 Car Number

Each car will be assigned a number at the time of its entry into a competition.



Car numbers must appear on the vehicle as follows:

- a) Locations: In three (3) locations: the front and both sides;
- b) Height: At least 15.24 cm (6 inch) high;
- c) Font: Block numbers (i.e. sans-serif characters). Italic, outline, serif, shadow, or cursive numbers are prohibited.
- d) Stroke Width and Spacing between Numbers: At least 2.0 cm (3/4 inch).
- e) Color: Either white numbers on a black background or black numbers on a white background. No other color combinations will be approved.
- f) Background shape: The number background must be one of the following: round, oval, square or rectangular. There must be at least 2.5 cm (1 inch) between the edge of the numbers and the edge of the background.
- g) Clear: The numbers must not be obscured by parts of the car, e.g. wheels, side pods, exhaust system, etc.

Car numbers for teams registered for North American FSAE competitions can be found on the “Registered Teams” section of the Formula SAE website.

Comment: Car numbers must be quickly read by course marshals when your car is moving at speed. Make your numbers easy to see and easy to read.

Example:



3.6.2 School Name

Each car must clearly display the school name (or initials – if unique and generally recognized) in roman characters at least 5.08cm, (2 inch) high on both sides of the vehicle. The characters must be placed on a high contrast background in an easily visible location.

The school name may also appear in non-roman characters, but the roman character version must be uppermost on the sides.

3.6.3 SAE Logo

The SAE logo must be displayed on the front and/or both sides of the vehicle in a prominent location. SAE logo stickers will be provided to the teams on site.

3.6.4 Technical Inspection Sticker Space

Technical inspection stickers will be placed on the upper nose of the vehicle. Cars must have a clear and unobstructed area at least 25.4 cm wide x 20.3cm high (10” x 8”) on the upper front surface of the nose along the vehicle centerline.

Vehicles that are being entered into multiple competitions in the FSAE series must allow sufficient space along the nose centerline for all inspection stickers.

3.7 General

3.7.1 Aero Dynamics and Ground Effects

All aerodynamic devices must satisfy the following requirements:

3.7.1.1 Location

In plan view, no part of any aerodynamic device, wing, undertray or splitter can be further forward than 460 mm (18 inches) forward of the fronts of the front tires, and no further rearward than the rear of the rear tires. No part of any such device can be wider than the outside of the front tires measured at the height of the front hubs.

3.7.1.2 Driver Egress Requirements

Egress from the vehicle within the time set in section 3.4.7 “Driver Egress,” must not require any movement of the wing or wings or their mountings. The wing or wings must be mounted in such positions, and sturdily enough, that any accident is unlikely to deform the wings or their mountings in such a way to block the driver’s egress.

3.7.1.3 Wing Edges - Minimum Radii

All wing leading edges must have a minimum radius 12.7 mm (0.5 inch). Wing leading edges must be as blunt or blunter than the required radii for an arc of plus or minus 45 degrees ($\pm 45^\circ$) centered on a plane parallel to the ground or similar reference plane for all incidence angles which lie within the range of adjustment of the wing or wing element. If leading edge slats or slots are used, both the fronts of the slats or slots and of the main body of the wings must meet the minimum radius rules.

3.7.1.4 Other Edge Radii Limitations

All wing edges, end plates, Gurney flaps, wicker bills, splitters undertrays and any other wing accessories must have minimum edge radii of at least 3 mm (1/8 inch) i.e., this means at least a 6 mm (1/4 inch) thick edge.

3.7.1.5 Wing Edge Restrictions

No small radius edges may be included anywhere on the wings in such a way that would violate the intent of these rules (e.g. vortex generators with thin edges, sharp square corners on end plates, etc.).

3.7.1.6 Ground Effect Devices – Prohibited

No power device may be used to move or remove air from under the vehicle except fans designed exclusively for cooling. Power ground effects are prohibited.



3.7.2 Fasteners

3.7.2.1 Grade Requirements

All threaded fasteners utilized in the steering, braking, driver's harness and suspension systems must meet or exceed, SAE Grade 5, Metric Grade 8.8 and/or AN/MS specifications.

3.7.2.2 Securing Fasteners

All critical bolt, nuts, and other fasteners on the steering, braking, driver's harness, and suspension must be secured from unintentional loosening by the use of positive locking mechanisms. Positive locking mechanisms include:

- Correctly installed safety wiring
- Cotter pins
- Nylon lock nuts
- Prevailing torque lock nuts

Note: Lock washers and thread locking compounds, e.g. Loctite®, DO NOT meet the positive locking requirement.

There must be a minimum of two (2) full threads projecting from any lock nut.

All spherical rod ends and spherical bearings on the steering or suspension must be in double shear or captured by having a screw/bolt head or washer with an O.D. that is larger than spherical bearing housing I.D.

Adjustable tie-rod ends must be constrained with a jam nut to prevent loosening.

3.7.3 Modifications and Repairs

(A) Once the vehicle has been presented for judging in the Cost or Design Events, or submitted for Technical Inspection, and until the vehicle is approved to compete in the dynamic events, i.e. all the inspection stickers are awarded, the only modifications permitted to the vehicle are those directed by the Inspector(s) and noted on the Inspection Form.

(B) Once the vehicle is approved to compete in the dynamic events, the **ONLY** modifications permitted to the vehicle are:

- a) Adjustment of belts and chains
- b) Adjustment of brake bias
- c) Adjustment of the driver restraint system, seat and pedal assembly
- d) Adjustment to engine operating parameters, e.g. fuel mixture and ignition timing
- e) Adjustment of mirrors
- f) Adjustment of the suspension where no part substitution is required, (except that springs, sway bars and shims may be changed)
- g) Adjustment of tire pressure

- h) Adjustment of wing angle
- i) Replenishment of fluids
- j) Replacement of worn tires or brake pads

The vehicle must maintain all required specifications, e.g. ride height, suspension travel, braking capacity, sound level and wing location throughout the competition.

(C) Once the vehicle is approved for competition, any damage to the vehicle that requires repair, e.g. crash damage, electrical or mechanical damage will void the Inspection Approval. Upon the completion of the repair and before re-entering into any dynamic competition, the vehicle **MUST** be re-submitted to Technical Inspection for re-approval.

3.7.4 Compressed Gas Cylinders and Lines

Any system on the vehicle that uses a compressed gas as an actuating medium must comply with the following requirements:

- (a) **Working Gas**-The working gas must be nonflammable, e.g. air, nitrogen, carbon dioxide.
- (b) **Cylinder Certification**- The gas cylinder/tank must be of proprietary manufacture, designed and built for the pressure being used, certified by an accredited testing laboratory in the country of its origin, and labeled or stamped appropriately.
- (c) **Pressure Regulation**-The pressure regulator must be mounted directly onto the gas cylinder/tank.
- (d) **Cylinder Location**- The gas cylinder/tank and the pressure regulator must be located within the structural portion of the Frame, e.g. they cannot be mounted in a non-structural side pod.
- (e) **Cylinder Mounting**- The gas cylinder/tank must be securely mounted to the Frame, engine or transmission.
- (f) **Cylinder Axis**- The axis of the gas cylinder/tank must not point at the driver.
- (g) **Insulation**- The gas cylinder/tank must be insulated from any heat sources, e.g. the exhaust system.
- (h) **Lines and Fittings**- The gas lines and fittings must be appropriate for the maximum possible operating pressure of the system.
- (i) **Protection**- The gas cylinder/tank and lines must be protected from damage resulting from the failure of rotating equipment.

3.7.5 High Pressure Hydraulic Pumps and Lines

The driver and anyone standing outside the car must be shielded from any hydraulic pumps and lines (other than brake lines) by steel or aluminum shields with a minimum thickness of 1 mm (0.039 inch).

3.8 Transponders

3.8.1 Transponders – North American FSAE competitions

Transponders will be used as part of the timing system for the dynamic events at the North American FSAE competitions

Each team is responsible for having a functional, properly mounted transponder of the specified type on their vehicle. Vehicles without a specified transponder will not be allowed to compete in any event for which a transponder is used for timing and scoring.

Note: Transponders may be used for timing and scoring at FSAE Australasia, FSAE Brazil, FSAE Italy and Formula Student and may be provided by the competition organizers. The transponders specified below for Formula SAE and Formula SAE West may or may not be compatible with the systems used for other events. Teams should check the individual competition websites for further details.

3.8.2 Transponder Requirement

All vehicles must be equipped with at least one AMB TranX260 Rechargeable or AMB TranX260 Direct Power transponder.



3.8.3 Transponder mounting

The transponder mounting requirements are:

- (a) **Orientation** – The transponder must be mounted vertically and orientated so the number can be read “right-side up”.
- (b) **Location** – The transponder must be mounted on the driver’s right side of the car forward of the front roll hoop. The transponder must be no more than 60 cm (24 in) above the track.
- (c) **Obstructions** – There must be an open, unobstructed line between the antenna on the bottom of the transponder and the ground. Metal and carbon fiber may



interrupt the transponder signal. The signal will normally transmit through fiberglass and plastic. If the signal will be obstructed by metal or carbon fiber, a 10.2 cm (4 in) diameter opening can be cut, the transponder mounted flush with the opening, and the opening covered with a material transparent to the signal.

(d) Protection – Mount the transponder where it will be protected from obstacles.



4. STATIC EVENTS

4.1 Static Events

The maximum possible scores in the static events are:

Technical Inspection	No points
Cost and Manufacturing Analysis	100 points
Presentation	75 points
<u>Design</u>	<u>150 points</u>
Total	325 points

4.2 Technical Inspection

4.2.1 Objective

The objective of technical inspection is to determine if the vehicle meets the FSAE rules requirements and restrictions and if, considered as a whole, it satisfies the intent of the Rules. For purposes of interpretation and inspection the violation of the intent of a rule is considered a violation of the rule itself.

4.2.2 Inspection & Testing Requirement

Each vehicle must pass all parts of technical inspection and testing, and bear the inspection stickers, before it is permitted to participate in any dynamic event or to run on the practice track. The exact procedures and instruments employed for inspection and testing are entirely at the discretion of the Chief Technical Inspector.

Technical inspection will examine all items included on the Inspection Form found on the SAE website plus any other items the inspectors may wish to examine to ensure conformance with the Rules.

All items on the Inspection Form must be clearly visible to the technical inspectors. Visible access can be provided by removing body panels or by providing removable access panels.

Once a vehicle has passed inspection, except as specifically allowed under 3.7.3 Modification and Repairs, it must remain in the “As-approved” condition throughout the competition and must not be modified.

Decisions of the inspectors and the Chief Scrutineer concerning vehicle compliance are final and are not permitted to be appealed.

Technical inspection is a non-scored activity.

Technical inspection is conducted only to determine if the vehicle complies with the requirements and restrictions of the Formula SAE rules.

Technical approval is valid only for the duration of the specific Formula SAE competition during which the inspection is conducted.



4.2.3 Inspection Condition

Vehicles must be presented for technical inspection in finished condition, i.e. fully assembled, complete and ready-to-run. Technical inspectors will not inspect any vehicle presented for inspection in an unfinished state.

Note: Cars may be presented for technical inspection even if final tuning and set-up has not been finished.

4.2.4 Inspection Process

Vehicle inspection will consist of three separate parts as follows:

Part 1 – Scrutineering

Each vehicle will be inspected to determine if it complies with the requirements of the rules. This inspection will include examination of the driver's equipment (Rule 3.4.2) and a test of the driver egress time (Rule 3.4.7).

Part 1 must be passed before a vehicle may apply for Part 2 or Part 3 inspection.

Part 2 – Tilt Table Tests

Each vehicle will be tested to insure it satisfies both the 45 degree (45°) fuel and fluid tilt requirement (Rule 3.5.3.6.1) and the 60 degree (60°) tilt table requirement (Rule 3.4.8.1).

Parts 1 and 2 must both be passed before a vehicle may apply for Part 3 inspection.

Part 3 – Noise, Master Switch, and Brake Tests.

Noise will be tested by the specified method (Rule 3.5.5.3). If the vehicle passes the noise test then its master switches will be tested (see Rule 3.4.9). If the vehicle passes both the noise and master switch tests then its brakes will be tested by the specified method (see Rule 3.2.5.1).

4.2.5 Correction and Re-inspection

If any part of a vehicle does not comply with the Rules, or is otherwise deemed to be a concern, then the team must correct the problem and have the car re-inspected.

The judges and inspectors have the right to re-inspect any vehicle at any time during the competition and require correction of non-compliance.

4.2.6 Inspection Stickers

Inspection stickers issued following the completion of any part of Technical Inspection will be placed on the upper nose of the vehicle as specified in 3.6.4 "Technical Inspection Sticker Space". Inspection stickers are issued contingent on the vehicle remaining in the required condition throughout the competition. Inspection stickers may be removed from vehicles that are not in compliance with the Rules or are required to be re-inspected.



4.3 Cost & Manufacturing Analysis Event

100 points

4.3.1 The Concept

The objective of the Cost and Manufacturing Event is twofold:

- To teach the participants that cost and a budget are significant factors that must be taken into account in any engineering exercise.
- For the participants to learn and understand the manufacturing techniques and processes of some of the components that they have chosen to purchase rather than fabricate themselves.

4.3.2 The Requirements

This event is comprised of two (2) parts:

- The preparation and submission of a written report (the “Cost Report”), which is to be sent to the Cost Judges prior to the competition. (See Section 4.3.4)
- A discussion at the Competition with the Cost Judges around the team’s vehicle. (See Section 4.3.5) This evaluates not only the cost of the car, but also the team’s ability to prepare accurate engineering and manufacturing cost estimates.

4.3.2.1 Formula SAE, Formula SAE at VIR & Formula SAE West Cost Reports

Teams that are entering more than one North American competition may submit one (1) Cost Report covering all the competitions entered providing that (a) the report is properly identified by the competition names and car numbers and (b) any addendum necessary to cover changes or modifications made to the vehicle between the events is properly completed and submitted.

4.3.3 Scoring

The points for the Cost and Manufacturing Event will be broken down as follows:

$30 \times \frac{(25,000 - P_{your})}{(25,000 - P_{min})}$	30 Points	Lowest cost - each of the participating schools will be ranked by total adjusted retail cost from the BOM and given 0-30 points based on the formula on the left. P_{your} is the adjusted cost of your car (with penalties), and P_{min} is the adjusted cost of the lowest cost car. If P_{your} is greater than \$25,000 US, the car will be disqualified from the Cost Event
	30 Points	The Cost Report – written, professional presentation of cost data. The report score will be given based on the quality of the cost report, its accuracy and thoroughness. The range for the report score is 0 –30 points.
	20 Points	Event Day/Visual Inspection - The cars will be reviewed for part content and manufacturing feasibility. 0-20 points.
	20 Points	Event Day/Manufacturing Processes - The teams must be prepared to discuss in detail the manufacturing processes for 2 items chosen at random from the list in Section 4.3.5. 0-10 points per item.
Total	100 Points	

4.3.4 The Cost Report

The Cost Report must be reflective of the prototype vehicle that the team has brought to the competition.

The Cost Report must fit in one three ring binder with 8.5”x11” or A4 pages no more than 5” thick.

Cost Report Identification

The cover of the Cost Report must include the following:

(a) university name, (b) competition name, and (c) vehicle number.

Note: Teams that are submitting a single Cost Report covering more than one North American competition should identify their report as follows:

University Name (full name)

Formula SAE, Car # XXX and Formula SAE West, Car #YYY

The Cost Report must consist of the following:

- A Cover sheet
- A Table of Contents
- A Cost Summary page listing each section’s cost, and the total vehicle cost
- Eight commodity report sections with the components placed in the sections as specified in Appendix A-3.
- Tabs for each section



Each commodity report section must include:

- A Bill of Materials (BOM) for that section, listing end items only, of the prototype that the team has brought to the competition.
- Up to ten pages of process descriptions (see below)
- Receipts
- Other backup material (prints, photos, et al)

Process Descriptions

Process descriptions are only done for parts your team made from scratch, or parts that were purchased and modified. Process descriptions are not done for purchased parts. These descriptions explain how a part was manufactured. Process descriptions for discussion at the competition should not be included in the report.

If more than ten (10) pages of process description are submitted, only the first ten (10) pages will be scored.

Bill of Materials (BOM)

The BOM must be divided into the eight (8) sections specified in Appendix A-3, and each section must follow the format given in Appendix A-4.

The BOM must have the columns as listed in A-4. The columns must be in the order shown in A-4, and there must be no other columns added, nor must any be eliminated. The BOM's are run through a program during judging prior to the event, and reports that do not follow the layout of A-4 will not be scored.

End Items – Definition

An end item is a part that is bolted onto the car as part of the final assembly process.

Examples:

A control arm. The control arm is made up of several tubes welded or bonded together, with rod ends threaded to the arm. The parts in the control arm assembly are not included in the BOM. The arm is then bolted to the frame. Thus the control arm is an end item part.

A brake caliper. The caliper is made up of a housing, piston(s), o-rings, nipple, bleeder screw, and a cap. The parts in the caliper assembly are not included on the BOM. The caliper, as it is bolted to the car is an end item.

If your team is unsure if a part belongs as an end item, feel free to ask the Rules Committee. Furthermore, a typical list of end items can be found in the appendix of these rules.



4.3.4.1 General Requirements

The Cost Report must:

- A. Reflect the actual, one-off, prototype vehicle brought to the event in terms of specification.
- B. List and cost every part on the prototype vehicle. This includes any equipment fitted on the vehicle at any time during the competition. The only exceptions are that, per Section 4.3.7 “Cost Report Exempt items” of the Rules, the cost of any finish, on-board fire suppression system, rain tires, or “stand-alone” data acquisition, video or radio system, does not need to be included in the Cost Report.
- C. Be based on the estimated costs of materials, fabrication and assembly of the car. The costs shall be calculated as defined in Section 4.3.6 “Cost Calculations” of these rules.
- D. Be based on the actual manufacturing technique used on the prototype, e.g. cast parts on the prototype should be cost as cast, and fabricated parts as fabricated, etc.

The reported cost of the prototype vehicle will exclude R & D, tooling (e.g. jigs, moulds, patterns and dies), and capital expenditures (e.g. plant, machinery and tools). The prototype vehicle’s calculated cost should not exceed \$25,000.00. If the cost exceeds this outer boundary, it will be disqualified from the Cost Event and receive zero (0) points for the event.

4.3.4.2 Receipts

- A. The receipts must be numbered and labeled, and attached to each sub-assembly section with the quantities stated.
- B. The full retail cost of parts must be used in the Cost Report. Discounted or wholesale prices are not to be used. If a part is used, donated or discounted, the full retail cost for said part must still be given.
- C. The supplier/retailer’s phone number must be included with each receipt.
- D. If the actual receipt for a part is not available, a photocopy of a page from a catalogue of the part in question will be acceptable.
- E. Receipts that are dated less than three (3) years prior to the Competition, i.e. no older than 3 years, are valid.

4.3.4.3 Report Submission and Deadline

- A. The submitted Cost Report must include both a printed (“hard”) copy and an electronic copy of the costed BOM.
- B. The printed (hard) copy of the report must be on 8 1/2 inch x 11 inch or A4 size paper, using a 10-point font size or larger.



- C. The electronic copy of the BOM must use Microsoft Excel on a single IBM compatible 3.5” disc or a CD ROM. It should NOT include copies of receipts or any back-up material.
- D. Submission Address and Deadline – The submission address and deadline will be published in the appendix or released on the website of the specific competition.

4.3.4.4 Late Submission of Cost Report

It is imperative that the cost judges have the Cost Reports in enough time for proper evaluation. Teams that submit reports with a postmark later than the specified date will be penalized -10 points per day late, with a maximum penalty of -80 points. Teams that do not submit a Cost Report will receive -100 points for the Cost & Manufacturing Analysis score.

4.3.4.5 Addenda

Any addendum that reflects any changes or corrections made after the submission of the Cost Report must be submitted at Registration when the Team registers on-site at the Event. It will not be accepted at any other time or place. The addendum document must follow the template format specified in Appendix A-2, and cannot be more than a single page. No other format will be accepted.

4.3.4.6 Cost Report Judging and Penalties

From the Bill of Material, the cost judges will determine if all parts and processes have been included in the analysis and if unreasonably low costs have been used (determined by the experience of the judges). In the case of any omission, error, or cost below reasonable, the judges will add a penalty equal to twice the cost error.

The team’s retail cost plus penalties will be used to determine the cost score. For example, if a car has tires listed at \$50 and the Cost Judges have evidence that the same or similar tires should actually cost \$110, then the judges will add 2 x \$60 for each tire to the cost. Errors of costs above reasonable prices are not penalized further and the error is not corrected. Further, the parts used in the cost estimate must be the actual parts used on the prototype and substitution of cheaper parts for the cost analysis is prohibited. For example, if styled wheels costing \$150 each are used on the prototype, then substitute wheels costing \$50 each can not be used in the cost analysis.

Cost Reports that have not made a serious attempt at an accurate cost estimate or that claim to have a cost that is substantially below what the Cost Judges know to be appropriate for cars of this type will be disqualified as unresponsive and will be scored as unsubmitted.



4.3.5 Discussion at the Competition

At this discussion, the Cost Judges will:

- A. Review whether the specification of the vehicle in the Cost Report accurately reflects the vehicle brought to the Competition,
- B. Review the manufacturing feasibility of the vehicle
- C. Require the team to outline the manufacturing processes involved for two (2) items chosen from the following list, which represents items that are normally purchased by the teams. The two (2) items for each team will be chosen at random at the event.
 - Oil Filter
 - Brake Caliper
 - Lug/Wheel nut
 - Rear view mirror
 - Electrical fuse
 - Steering wheel
 - Spherical rod end
 - Ignition Coil

The team must present their vehicle at the designated time to the Cost Judges for review of the cost report. Teams that miss their cost appointment will potentially lose all cost points for that day. The schedule for these appointments will be in the registration packets and/or posted on the website.

4.3.6 Cost Calculations

The costs to be entered into the Cost Report include the component costs and the costs of assembling components into sub-assemblies and assembling the sub-assemblies into the vehicle.

4.3.6.1 Component Costs

Component costs consist of the material cost and the cost of the process(es) to manufacture the component. The time required to load, unload, machine, paint, fabricate, etc. is cost at \$35/hour if it is not explicitly cost in the Operations Cost Table. The table given in Rule 4.3.9 “Costing Tables” provides some guidelines to the cost of various operations. Do not include overhead, costs of expendables, capital costs, and depreciation of machine equipment.

The components on a team’s (prototype) car can be from several sources. They can be purchased new, purchased used, donated, “pirated” from a previous year’s car, modified from an acquired part, or fabricated/manufactured from basic raw materials. The cost calculations must follow the following guidelines:

- A. **Purchased New Part** – Use the full retail cost, even if it was actually acquired with a discount. (See Appendix A-4, example #1).



- B. **Purchased Used, Donated or “Pirated” Parts** – Use the full retail cost of a “new” part of exactly the same specification.
- C. **Modified (Purchase and Alter) Part** – Use the full retail cost of the part as above, plus the cost of the modifications taken from the Operations Cost Table in Section 4.3.9 of the Rules.
- D. **Fabricated/Manufactured Part** – Use the Common Materials Cost Minimums Table from 4.3.9 to determine the cost of the basic material, bearing in mind that the weight of the material must include any scrap from cutting or machining. If the material is not listed in 4.3.9, a receipt for the material used must be provided. The cost of making the part will then be added using the rates from the Operations Cost Table of 4.3.9.

The parts costs used must be the “full retail” cost of the part in question. Wholesale or discounted costs are not to be used, whether they be “educational”, volume or for other reasons.

Note that in calculating the labor costs to modify or fabricate a part, the team should assume that the process has been refined and reflects the time it would take if the part in question was being fabricated on a regular basis. The Cost Judges recognize that the time taken to make parts for the team’s actual prototype vehicle will have been far longer. Examples of cost calculations are given in Section 4.3.10 of these rules.

4.3.6.2 Labor and Assembly Costs

- A. Assembly labor is to be cost at \$35.00 US per hour.
- B. Assembly of a component is to be included in the cost of that component.
- C. Assembly of components into a sub-assembly is to be listed as a separate line item in the section of the BOM in which that sub-assembly appears.
- D. Assembly of a sub-assembly or assembly onto the vehicle is to be listed as another separate line item in the section of the BOM in which that assembly appears.

4.3.7 Cost Report Exempt Items

4.3.7.1 Finishes

The car will be considered to be shipped as primed or gel coated and a cost recorded. Any finishes (paint, polish, etc.) that are only used to beautify need not be costed. Preservative finishes intended to protect the appearance or function of a component for an extended period of time must be costed (labor and material included).

4.3.7.2 Fire Extinguisher and Suppression System

Hand held fire extinguishers are not allowed on the vehicle (See Rule 3.4.10.2 “Fire Extinguishers”), but if the car has an on-board fire suppression system, it is not required to be costed.

4.3.7.3 Tires and Wheels

Only one set of tires and wheels needs to be included in the Cost Report. The tires and wheels that are declared as dry tires per rule 3.2.2 “Wheels and Tires” must be the tires included in the Cost Report, and must be the tires on the car during the cost event judging. Other tires that will be potentially used at the competition (i.e. rain tires) do not need to be included in the Cost Report.

4.3.7.4 Transponders, Data Acquisition, Video and Radio Systems

Transponders, “stand-alone” data acquisition, video and radio systems, and their associated sensors, need not be included in the Cost Report. A “stand-alone” system is one that can be removed from the vehicle without affecting the vehicle’s ability to perform. Teams that claim to be using a “stand-alone” system may be required to remove the system to substantiate their claim.

4.3.8 Engine Costing

The cost of the engine depends upon the performance rating of the engine. The engine performance rating is based upon the power potential of the manufacturer’s specification of the engine without the required restrictor. The engine is considered low performance if it is capable of producing less than 5 horsepower per 100 cc displacement (industrial engines, etc.). A high performance engine is capable of 5-10 horsepower per 100 cc (normal motorcycle engines with 2 valves per cylinder, etc.). An ultra high performance engine is capable of more than 10 horsepower per 100 cc (new high tech engines, 3- or 4-valves per cylinder, etc.).

The engine is considered to be purchased with all of the required components and systems necessary to run. The engine costs listed below include the transmission/CVT device regardless of whether it is integral to the engine or not. Engines that come equipped with an integral transmission, differential, and U-jointed axles must estimate the cost of the differential and U-joints separately.

Items driven by, or beyond the general function of, the engine and/or transmission must be costed. All other items: the carburetor (or fuel injection system), the ignition and/or electrical system (including spark plug(s), coils and wires), turbo or supercharger if used, the intake manifold, the exhaust manifold, cooling system (water & oil), and mufflers must be costed. These costs must be listed separately in the cost analysis.

The following table lists the costs of the engine:

RATING	ENGINE & TRANSMISSION/CVT
Low	\$ 0.60/cc
High	\$ 1.00/cc
Ultra-high	\$ 1.25/cc

4.3.9 Costing Tables

To assist in your process the following tables must be used in costing:

COMMON MATERIALS AND COST MINIMUMS TABLE

Mild steel, e.g. 1010, 1025	\$0.30/pound
Alloy steel, e.g. 4130, Chrome Moly	\$0.60/pound
Aluminum	\$0.75/pound
Magnesium	\$2.25/pound
Non-graphite composites	\$88.18/kg (\$40/pound)
Graphite-based composites	\$220.50/kg (\$100/pound)

This table represents the lowest cost of these materials allowed. Regardless of what price a team actually paid for the material and/or what the receipts show the cost as, this table represents the **MINIMUM** cost.

Other materials such as plastics span such a vast range of uses and costs that a common price standard is impractical. Cost for composites and structural construction similar to fiberglass should be cost separately with a clear identification of the costs of all materials and processes. Obviously, process costs are in addition to the above material cost minimums.

OPERATIONS COST TABLE

Labor (all activity)	\$35.00 / hr.
CNC Machine (time)	\$70.00 / hr.
Computer aided labor, e.g. water jet cutting	\$70.00 / hr
Welds	\$0.14 / cm (\$0.35/inch)
Saw or tubing cuts	\$0.16 / cm (\$0.40/inch)
Tube bends	\$0.75 / bend
Non-metallic cutting	\$0.08 / cm (\$0.20 /inch)
Tube end preparation for welding	\$0.75 / end
Drilled holes less than 1" diameter, any depth	\$0.35 / hole
Drilled hole greater than 1" diameter	\$0.35 / inch / hole
Reamed hole	\$0.35 / hole
Tapping holes	\$0.35 / hole
Sheet metal shearing	\$0.20 / cut
Sheet metal punching	\$0.20 / hole
Sheet metal bends	\$0.05 / bend
Sheet metal stampings (process cost only)	\$0.008 / sq. cm (\$0.05 / in ²)
Sand castings (process cost only)	\$6.61 / kg (\$3.00 / pound)
Die castings (process cost only)	\$8.82 / kg (\$4.00 / pound)
Investment casting (process cost only)	\$17.64 / kg (\$8.00 / pound)
Plastic injection molding (process cost only)	\$6.06 / kg (\$2.75 / pound)

4.3.10 Examples of Process Descriptions

4.3.10.1 Purchase Example

The team purchased 3 Widget “A’s” from Amalgamated Auto for \$12 each on sale and they retail for \$15. No process need be written for this part, it does have to be listed in the Bill of Material (See Appendix A-4, example #1).

Name: Widget A							
Purchased Component	Material						
	Sub.	Qty.	Description	Volume	Weight	\$/Unit	Cost
	A	3	Widget A			\$15.00	\$45.00
							Total

This data would be listed in the BOM as in Appendix A-4, example #1. There would be no material in the process description sheets as this is a purchased, unmodified part.

4.3.10.2 Purchased and Altered Example

A component requiring detail process would be as follows – the team purchased 3 Widget B’s” from Amalgamated Auto for \$12 each on sale and they retail for \$15. You altered each of them by cutting two surfaces on the mill @ 5 minutes each.

Purchase component, then modify.	Name: Widget B							
	Material							
	Sub.	Qty.	Description	Volume	Weight	\$/Unit	Cost	
	A	3	Widget B			\$15.00	\$45.00	
	Process Labor							
	Sub.	Qty.	Amount	Unit	Manning	Description	\$/Unit	Cost
	A	3	10	Min.	1	Mill Slot	\$5.83	\$17.50
							Total	\$62.50

This data would be listed in the BOM as in Appendix A-4, example #2. The process description would be in the ten-page written report pertaining to this section of the car.

4.3.10.3 Manufactured Example

The team purchased or had on hand a round piece of aluminum bar stock 2" diameter x 7.5" long. The piece was centered and cut on a lathe that was set up for production (would take 10 minutes) and milled in two slots (5 minutes each). Additionally, they drilled four holes less than 1" in diameter and tapped two of them.

The process sheet could look as follows:

Team Manufactured Part	Name: Widget C							
	Material							
	Sub.	Qty.	Description	Volume	Weight	\$/Unit	Cost	
	A	3	Al bar - round 2" dia. X 7.5"	23.56	2.356	\$0.75	\$1.77	
							Subtotal	\$1.77
	Process Labor							
	Sub.	Qty.	Amount	Unit	Manning	Description	\$/Unit	Cost
	A	1	10	Min.	1	Lathe cut	\$0.58	\$5.83
	A	2	5	Min.	1	Mill Slot	\$0.58	\$5.83
	A	4	1	Holes	1	Drill Hole	\$0.35	\$1.40
	A	2	1	Holes	1	Tap Hole	\$0.35	\$0.70
							Subtotal	\$13.76
							Total	\$15.53

This data would be listed in the BOM as in Appendix A-4, example #3. The process description would be in the ten-page written report pertaining to this section of the car.



Note: If Widget “C” were a component such as an exhaust manifold, the welding and fixture time would be listed here and not in final assembly. Each individual component and process would have its own sub number or letter assignment. The total component cost would then be added to the BOM as a single line item.

4.3.10.4 Off-Line Assembly Example

The team manufactured Widget “D” and purchased Widgets “E” and “F” (all of which are listed in the BOM) and assemble them at an offline assembly operation. It took 10 minutes. This is a final assembly cost and would be a part of the total assembly cost listed at the end of the BOM (See A-4, example #4).

4.3.11 Exchange Rates

It is mandatory that the Cost Report be submitted in US dollars. Teams that purchase components in other currencies must convert the costs of those components into US dollars using the official “Daily 12 noon buying” rate(s) for the first business day, e.g. January 2nd, of the year of the competition published on the web site of the Federal Reserve Bank of New York at: www.ny.frb.org

4.3.12 Taxes

The cost of the parts must not include any taxes paid on them when purchased.



4.4 Presentation Event

75 points

4.4.1 Presentation Event Objective – Business Case

The objective of the presentation event is to evaluate the team's ability to develop and deliver a comprehensive business case that will convince the executives of a manufacturing firm that the team's design best meets the demands of the amateur, weekend, autocross/Sports Car Club of America (SCCA) Solo II racing market and that it can be profitably manufactured and marketed.

The judges should be treated as if they were executives of the manufacturing firm. Teams should assume that the executives represent different areas of a corporate organization, including engineering, production, marketing and finance, and thus may not all be engineers. Presentations will be evaluated on the contents, organization and visual aids as well as the presenters' delivery and the team's response to questions. The presentation must relate to the car entered into the competition although the actual quality of the prototype itself will not be considered as part of the presentation judging.

4.4.2 Presentation Schedule

Presentations will be made on the static events day. Presentation times will be scheduled by the organizers and either, or both, posted in advance on the competition website or released during on-site registration.

Teams that fail to make their presentation during their assigned time period will receive zero (0) points for the event.

4.4.3 Presentation Format

One or more team members will give the presentation to the judges. All team members who will give any part of the presentation, or who will respond to the judges' questions, must be in the podium area when the presentation starts and must be introduced to the judges. Team members who are part of this "presentation group" may answer the judge's questions even if they did not speak during the presentation itself.

Presentations are limited to a maximum of ten (10) minutes. The judges will stop any presentation exceeding ten minutes. The presentation itself will not be interrupted by questions. Immediately following the presentation there will be a question and answer session of up to five (5) minutes. Only judges may ask questions. Only team members who are part of the "presentation group" may answer the judges' questions.

4.4.3.1 Data Projection Equipment

Projection equipment is not provided by the organizers. Teams planning to use data projectors, or any type of projectors, as part of their presentation are responsible for bringing, or otherwise arranging for, their own projection equipment.



4.4.4 Evaluation Criteria

Presentations will be evaluated on content, organization, visual aids, delivery and the team's response to the judges' questions. The scoring criteria are detailed in Appendix A-5 "Presentation Judging". The criteria are applied only to the team's presentation itself. The team that makes the best presentation, regardless of the quality of their car, will win the event.

4.4.5 Scoring Formula

The scoring of the event is based on the average of the two or three presentation judging forms. There is a maximum of fifty (50) points from the Presentation Judging Form.

$$\text{PRESENTATION SCORE} = 75 \times P_{\text{your}}/P_{\text{max}}$$

Where:

"P_{max}" is the highest score awarded to any team

"P_{your}" is the score awarded to your team

It is intended that the scores will range from near zero (0) to seventy-five (75) to provide good separation. The Presentation Event Captain may at his/her discretion; normalize the scores of different judging teams.



4.5 Design Event

150 points

4.5.1 Design Event Objective

The concept of the design event is to evaluate the engineering effort that went into the design of the car and how the engineering meets the intent of the market. The car that illustrates the best use of engineering to meet the design goals and the best understanding of the design by the team members will win the design event.

Comment: Teams are reminded that FSAE is an engineering design competition and that in the Design Event, teams are evaluated on their design. Components and systems that are incorporated into the design as finished items are not evaluated as a student designed unit, but are only assessed on the team's selection and application of that unit. For example, teams that design and fabricate their own shocks are evaluated on the shock design itself as well as the shock's application within the suspension system. Teams using commercially available shocks are evaluated only on selection and application within the suspension system.

4.5.2 Design Report and Design Spec Sheet – Submission Requirements

(a) Design Report - Judging will start with a Design Review before the event. The principal document submitted for the Design Review is a Design Report. This report must not exceed eight (8) pages, consisting of not more than four (4) pages of text, three (3) pages of drawings (see 4.5.2.1, "Vehicle Drawings") and one (1) optional page containing content to be defined by the team (photo's, graphs, etc...). This document should contain a brief description of the vehicle with a discussion of any important design features and vehicle concepts. Include a list of different analysis and testing techniques (FEA, dynamometer testing, etc.). Evidence of this analysis and back-up data should be brought to the competition and be available, on request, for review by the judges. These documents will be used by the judges to sort teams into the appropriate design groups based on the quality of their review.

Comment: Consider your Design Report to be the "resume of your car".

(b) Design Spec Sheet - In addition to the above document, a completed FSAE Design Spec Sheet must also be submitted. The FSAE Design Spec Sheet template can be found on the FSAE website at: <http://www.sae.org/students/fsae-designspecs.xls>. Do not alter or re-format the template prior to submission.

The design judges realize that final design refinements and vehicle development may cause the submitted figures to diverge slightly from those of the completed vehicle. For specifications that are subject to tuning, an anticipated range of values may be appropriate.

The Design Report and the Design Spec Sheet, while related documents, should stand alone and be considered two (2) separate submissions. Two separate file submissions are required.



4.5.2.1 Vehicle Drawings

The Design Report must include one set of 3 view drawings showing the vehicle, from the front, top, and side. Each drawing shall appear on a separate page. The drawings can be manual or computer generated. Photos should be placed on the optional page and will not be counted as drawings.

4.5.3 Design Report and Design Spec Sheet Formats

The Design Report must be submitted electronically in Adobe Acrobat® Format (*.pdf file). This document must be a single file (text, drawings, and optional content all inclusive). The Design Report file must be named as follows:

carnumber_schoolname.pdf using the FSAE assigned car number and the complete school name, e.g. 001_University of SAE.pdf

Design Spec Sheets must be submitted electronically in Microsoft Excel® Format (*.xls file). The format of the Spec Sheet **MUST NOT** be altered. Similar to the Design Report, the Design Spec Sheet file must be named as follows:

carnumber_schoolname_specs.xls using the FSAE assigned car number and the complete school name, e.g. 001_University of SAE_spec.xls

WARNING – Failure to exactly follow the above submission requirements may result in exclusion from the Design Event. If your files are not submitted in the required format or are not properly named then they cannot be included in the documents provided to the design judges and your team will be excluded from the event.

4.5.4 Excess Size Design Reports

If a team submits a Design Report that exceeds four (4) pages of text, three (3) pages of drawing and one (1) optional page, then only the first four pages of text, three pages of drawings and first optional page will be read and evaluated by the judges. Note: If included, cover sheets and tables of contents will count as text pages.

4.5.5 Submission Deadlines

The Design Report and the Design Spec Sheets must arrive at the specified e-mail address by the date shown in the Action Deadlines for the competition your team is entering. E-mail the Design Report and Design Spec Sheets to the address provided in the appendix. The two files must be e-mailed as separate files.

You will receive confirmation of receipt via email and/or the event website once report is reviewed for accuracy. Teams should have a printed copy of this reply available at the competition as proof of submission in the event of discrepancy.



4.5.6 Penalty for Late Submission or Non-Submission

Teams who do not submit a Design Report and a Design Spec Sheet by the specified deadline will not compete in the design event, and will receive zero (0) points for design.

4.5.7 Penalty for Unsatisfactory Submissions

At the discretion of the judges, teams that submit a Design Report or a Design Spec Sheet which is deemed to be unsatisfactory, will also not compete in the design event, but may receive between five (5) and twenty (20) pts. for their efforts.

4.5.8 Design Event – Vehicle Condition

Cars must be presented for design judging in finished condition, i.e. fully assembled, complete and ready-to-run. The judges will not evaluate any car that is presented at the design event in what they consider to be an unfinished state. Unfinished cars that are refused judging will receive zero (0) points for design. Point penalties may be assessed for cars with obvious preparation issues, e.g. notably loose or missing fasteners.

Note: Cars can be presented for design judging without having passed technical inspection, even if final tuning and setup is in progress.

4.5.9 Judging Criteria

The design judges will evaluate the engineering effort based upon the team's Design Report, Spec Sheet, responses to questions and an inspection of the car. The design judges will inspect the car to determine if the design concepts are adequate and appropriate for the application (relative to the objectives set forth in the rules). It is the responsibility of the judges to deduct points on the design judging form, as given in Appendix A-6, if the team cannot adequately explain the engineering and construction of the car.

4.5.10 Judging Sequence

The actual format of the design event may change from competition to competition and year to year as determined by the organizing body. At Formula SAE and Formula SAE West, Design Judging will normally involve three parts:

1. Initial judging of all vehicles
2. Semi- final judging of the top 10 to 20 vehicles
3. Final judging ranking the top 4 to 8 vehicles.

At other competitions in the Formula SAE Series Design Judging may be in one or two parts.



4.5.11 Scoring

Scoring will be from 0 to 150 pts. at the judges discretion.

4.5.12 Photographic Requirements

All teams should provide photos of their vehicle upon entering the design tent. These photos should show the basic design of the major components. At least four photos are recommended. These photos are to aid the judges in selecting semi-finalists and are not the photos that will be used for yearly documentation.

4.5.13 Second Year Cars - Penalties For Insufficient Redesign

Formula SAE Australasia, Formula SAE Brasil, Formula SAE Italy, and Formula Student

The judges will deduct 20 points from the final design score for cars without a new frame. An additional 30 points may be deducted if the photographic documentation shows that the remaining parts of the vehicle have not been significantly changed (e.g. the intake manifold is obviously the same or it is obvious that the old suspension was simply bolted to a new frame, or none of the team members show an understanding of the design of various components). If the new frame is similar to last years, it is advisable to bring along evidence of the change (bringing along the old frame is not a bad idea).

Second year cars are prohibited at the North American FSAE competitions.



5. DYNAMIC EVENTS

5.1 Dynamic Events

The maximum scores in the dynamic events are:

Acceleration	75 points
Skid Pad	50 points
Autocross	150 points
Fuel Economy	50 points
<u>Endurance</u>	<u>350 points</u>
Total	675 points

5.1.1 Vehicle Integrity and Disqualification

During the Dynamic Events, the mechanical integrity of the vehicle must be maintained. Any vehicle condition that could compromise vehicle integrity, e.g. damaged suspension, brakes or steering components, or could compromise the track surface, e.g. fluid leaks or dragging bodywork, will be a valid reason for exclusion by the officials until the problem is rectified.

Note: If this happens during the Endurance Event, it means disqualification from the heat.

5.2 Weather Conditions

The organizer reserves the right to alter the conduct and scoring of the competition based on weather conditions.

5.2.1 Running in Rain

5.2.1.1 Operating Conditions

The following operating conditions will be recognized at Formula SAE:

Dry – Overall the track surface is dry.

Damp – Significant sections of the track surface are damp.

Wet – The entire track surface is wet and there may be puddles of water.

Weather Delay/Cancellation – Any situation in which all, or part, of an event is delayed, rescheduled or canceled in response to weather conditions.

5.2.1.2 Decision on Operating Conditions

The operating condition in effect at any time during the competition will be decided by the competition officials.



5.2.1.3 Notification

If the competition officials declare the track(s) to be "Damp" or "Wet",

- i. This decision will be announced over the public address system, and
- ii. A sign with either "Damp" or "Wet" will be prominently displayed at both the starting line(s) or the start-finish line of the event(s), and the entry gate to the "hot" area.

5.2.1.4 Tire Requirements

The operating conditions will determine the type of tires a car may run as follows:

Dry – Cars must run their Dry Tires, except as covered in 5.2.1.8.B.iii.

Damp – Cars may run either their Dry Tires or Rain Tires, at each team's option.

Wet – Cars must run their Rain Tires.

5.2.1.5 Event Rules

All event rules remain in effect.

5.2.1.6 Penalties

All penalties remain in effect.

5.2.1.7 Scoring

No adjustments will be made to teams' times for running in "Damp" or "Wet" conditions. The minimum performance levels to score points may be adjusted if deemed appropriate by the officials.

5.2.1.8 Tire Changing

(A) During the Acceleration, Skid-Pad or Autocross Events:

Within the provisions of 5.2.1.4 above, teams may change from Dry Tires to Rain Tires or vice versa at any time during those events at their own discretion.

(B) During the Endurance Event:

Teams may change from Dry to Rain Tires or vice versa at any time while their car is in the staging area inside the "hot" area.

All tire changes after a car has received the "green flag" to start the Endurance Event shall take place in the Driver Change Area.

- (i) If the track was "Dry" and is declared "Damp":
 - Teams may start on either Dry or Rain Tires at their option.
 - Teams that are on the track when it is declared "Damp", may elect, at their option, to pit in the Driver Change Area and change to Rain



Tires under the terms spelled out below in "Tire Changes in the Driver Change Area".

- (ii) If the track is declared "Wet":
 - A Red Flag will be shown at the Start/Finish Line and all cars will enter the Driver Change Area.
 - Those cars that are already fitted with "Rain" tires will be allowed re-start without delay subject to the discretion of the Event Captain/Clerk of the Course.
 - Those cars without "Rain" tires will be required to fit them under the terms spelled out below in "Tire Changes in the Driver Change Area". They will then be allowed to re-start at the discretion of the Event Captain/Clerk of the Course.

- (iii) If the track is declared "Dry" after being "Damp" or "Wet":
 - The teams will NOT be required to change back to "Dry" tires.

- (iv) Tire Changes at Team's Option:
 - Within the provisions of 5.2.1.4 above and 5.2.1.8.B.v below, a team will be permitted to change tires at their option.
 - If a team elects to change from "Dry" to "Rain" tires, the time to make the change will NOT be included in the team's total time.
 - If a team elects to change from "Rain" tires back to "Dry" tires, the time taken to make the change WILL be included in the team's total time for the event, i.e. it will not be subtracted from the total elapsed time. However, a change from "Rain" tires back to "Dry" tires will not be permitted during the driver change.
 - To make such a change, the following procedure must be followed:
 - Team makes the decision,
 - Team has tires and equipment ready near Driver Change Area,
 - The team informs the Event Captain/Clerk of the Course they wish their car to be brought in for a tire change,
 - Officials inform the driver by means of a sign or flag at the checker flag station,
 - Driver exits the track and enters the Driver Change Area in the normal manner.



- (v) Tire Changes in the Driver Change Area:
- Per Rule 5.7.8, no more than three people for each team may be present in the Driver Change Area during any tire change, e.g. a driver and two crew or two drivers and one crew member.
 - No other work may be performed on the cars during a tire change.
 - Teams changing from "Dry" to "Rain" tires will be allowed a maximum of ten (10) minutes to make the change.
 - If a team elects to change from "Dry" to "Rain" tires during their scheduled driver change, they may do so, and the total allowed time in the Driver Change Area will be thirteen (13) minutes.
 - The time spent in the driver change area of less than 10 minutes without driver change, or 13 minutes with driver change, will not be counted in the team's total time for the event. Any time in excess of these times will be counted in the team's total time for the event.

5.3 Driver Limitations

An individual team member may not drive in more than three (3) events. The fuel economy event is considered a separate event although it is conducted simultaneously with the endurance event.

An individual may not drive in both heats of any event. It is the team's option to participate in any event. The team may forfeit their second heat in any performance event.

Note: At competitions where Endurance and Fuel Economy is run with one (1) heat a minimum of four (4) drivers are required to participate in all heats of the dynamic events. At competitions where Endurance and Fuel Economy is run with two (2) heats a minimum of five (5) drivers are required to participate in all heats of the dynamic events.



5.4 Acceleration Event

75 points

5.4.1 Acceleration Objective

The acceleration event evaluates the car's acceleration in a straight line on flat pavement.

5.4.2 Acceleration Procedure

The cars will accelerate from a standing start over a distance of 75 m (82 yards) on a flat surface. The foremost part of the car will be staged at 0.30 m (11.8 inches) behind the starting line. A green flag will be used to indicate the approval to begin, however, time starts only after the vehicle crosses the start line. There will be no particular order of the cars in each heat. A driver has the option to take a second run immediately after the first.

5.4.3 Acceleration Heats

There will be two (2) heats. Each heat must have a different driver and each driver can have two (2) runs. Starting order will be based upon time of arrival to the staging area. Heat one (1) and heat two (2) will not be run sequentially, but simultaneously. Heat 1 drivers will have starting priority over heat 2 drivers.

5.4.4 Tire Traction – Limitations

Special agents that increase traction may not be added to the tires or track surface and “burnouts” are not allowed.

5.4.5 Acceleration Scoring

The acceleration score is based upon the corrected elapsed time. Elapsed time will be measured from the time the car crosses the starting line until it crosses the finish line.

5.4.5.1 Cones Down Or Out (DOO)

A two (2) second penalty will be added for each DOO (including entry and exit gate cones) that occurred on that particular run to give the corrected elapsed time.

5.4.5.2 Off Course

An Off Course (OC) will result in a DNF for that run.

Cars that have not run by the end of the event (determined by the organizer) will receive a Did Not Finish (DNF).



5.4.6 Acceleration Scoring Formula

The score for the acceleration event is spread between zero (0) and seventy-five (75) based upon the elapsed time. The following equation is used to determine the scores for the event:

$$\text{ACCELERATION SCORE} = 71.5 \times \frac{(5.8/T_{\text{your}}) - 1}{(5.8/T_{\text{min}}) - 1} + 3.5$$

Where:

T_{your} is the best corrected elapsed time for the team including penalties.

T_{min} is the elapsed time of the fastest car.

The maximum acceptable acceleration time is 5.8 seconds corresponding to an average speed of 46.55 km/hr.

Negative “performance” points will not be given. However, 3.5 points will be given for a car that completes a run, even if T_{your} exceeds 5.8 seconds.

In the above equation, the first term on the right hand side is “performance” points”, while the second term represents “completion points,” or the minimum score for having successfully completed the event.

DNF = zero (0) points



5.5 Skid-Pad Event

50 Points

5.5.1 Skid-Pad Objective

The objective of the skid-pad event is to measure the car's cornering ability on a flat surface while making a constant-radius turn.

5.5.2 Skid-Pad Heats

Each car may compete in two heats. Each heat must have a different driver, and each driver may have two (2) runs.

Two separate skid-pad locations may exist. Heat one (1) will be run on skid-pad one (1) and Heat two (2) will be run on skid-pad two (2).

Heat one (1) drivers must complete both of their runs on skid-pad one (1), and heat two (2) drivers must complete both their runs on skid-pad (2).

If there is only one skid-pad location, then both Heat one (1) and Heat two (2) will be run on the same skid-pad at the same time.

5.5.3 Skid-Pad Heat Priority

There will be no distinction between Heat one (1) and Heat two (2) and there will be no particular starting order. Heat one (1) drivers will have a starting priority over Heat two (2) drivers. Cars which have not run by the event closing (determined by the organizer) will receive a DNF for the event.

5.5.4 Skid-Pad Layout

There will be two (2) pairs of concentric circles in a figure of eight pattern. The centers of these circles will be 18.25 m (59.88 feet) apart. The inner circles will be 15.25 m (50.03 feet) in diameter, and the outer circles will be 21.25 m (69.72 feet) in diameter. The driving path will be the 3.0 m (9.84 feet) path between the inner and outer circles. The cars will enter and exit through gates on a 3.0 m wide path that is tangential to the circles where they meet.

The line between the centers of the circles defines the start/stop line. A lap is defined as traveling around one (1) of the circles from the start/stop line and returning to the start/stop line.

FSAE SKIDPAD LAYOUT

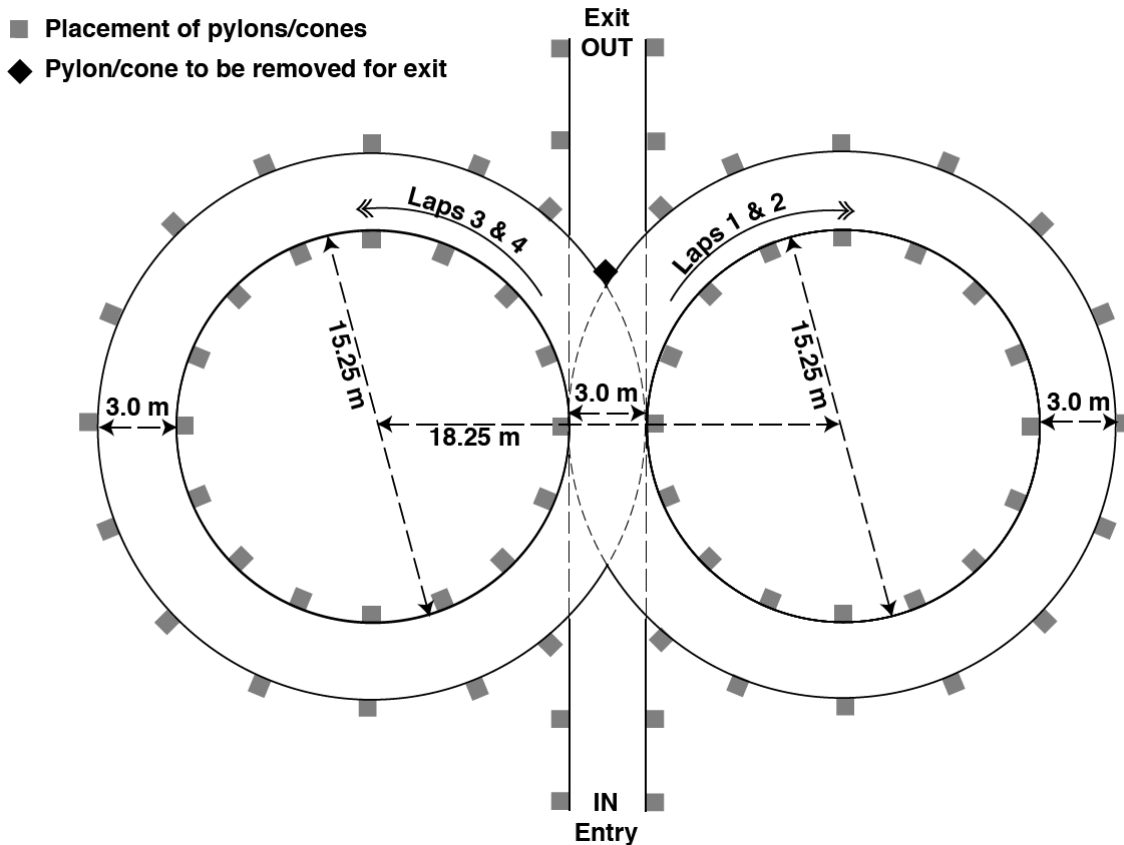

5.5.5 Skid-Pad Layout – Marking

Sixteen (16) pylons will be placed around the inside of each inner circle and sixteen (16) pylons around the outside of each outer circle. Each circle will be marked with a chalk line, inside the inner circle and outside the outer circle, i.e. not on the driving path. Additional pylons will establish the required entry and exit gates. Also, a cone will be placed in the middle of the exit gate to prevent unintended exits until the finish lap.

Note: The diagram in section 5.5.4 shows the circles for cone placement, not for course marking. Chalk lines are marked on the opposite side of the cones, i.e. not in the driving path.

5.5.6 Skid-Pad Procedure

The cars will enter perpendicular to the figure eight and will take one full lap on the right circle to establish the turn. The next lap will be on the right circle and will be timed. Immediately following the second lap, the car will enter the left circle for the



third lap. The fourth lap will be on the left circle and will be timed. Immediately upon finishing the fourth lap, the car will exit the track. The car will exit at the intersection moving in the same direction as entered. A driver has the option to take a second run immediately after the first.

5.5.7 Skid-Pad Penalties

The elapsed time for the right and left circle will be averaged together after the following penalties have been assessed.

5.5.7.1 Cones Down Or Out (DOO)

A penalty of 0.25 seconds will be added to the time for every cone that is knocked “down or out” (including gate cones).

5.5.7.2 Off Course

Cars that spin-out can continue as long as they have not gone off course. Cars going off course will be classified as DNF.

5.5.7.3 Incorrect Laps

Cars that do not follow 5.5.6 above, i.e. run an incorrect number of laps or run the laps in the wrong sequence will be classified as DNF.

5.5.8 Skid-Pad Scoring

The skid-pad score is computed based upon the lateral acceleration capability. Lateral acceleration (typically referred to as G’s) is computed from $2.012 \text{ diameter}/t^2$. A diameter of 17.10 m will be assumed in computing lateral G’s. If there are two separate skid-pad locations, then the score will be based on the best run from either skid-pad.

The first term on the right-hand side of the equation represent “performance points,” while the second term represents “completion points,” or the minimum score for having successfully completed the event. The following equation is used to determine the scores for the skid-pad event:

$$\text{SKID PAD SCORE} = 47.5 \times \frac{(6.184/T_{\text{your}})^2 - 1}{(6.184/T_{\text{min}})^2 - 1} + 2.5$$

Where:

T_{your} is the average of the left and the right timed laps on your best run including penalties.

T_{min} is the elapsed time of the fastest car.

The minimum acceptable lateral acceleration to earn “performance” points is 0.90 G’s corresponding to 6.184 seconds per circle. Negative “performance” points will not be given. However, 2.5 points will be given if a car that completes a run that exceeds 6.184 seconds per circle AND is not classified as a DNF.



5.6 Autocross Event

150 Points

5.6.1 Autocross Objective

The objective of the autocross event is to evaluate the car's maneuverability and handling qualities on a tight course without the hindrance of competing cars. The autocross course will combine the performance features of acceleration, braking, and cornering into one event.

5.6.2 Autocross Procedure

There will be two (2) Autocross-style heats, with each heat having a different driver. Two (2) timed laps will be run (weather and time permitting) by each driver and the best lap time will stand as the time for that heat.

The car will be staged such that the front wheels are 6 m (19.7 feet) behind the starting line. The timer starts only after the car crosses the start line.

There will be no particular order of the cars to run each heat but a driver has the option to take a second run immediately after the first.

The organizer will determine the allowable windows for each heat and retains the right to adjust for weather or technical delays. Cars that have not run by the end of the heat will be disqualified for that heat.

5.6.3 Autocross Course Specifications & Speeds

The following specifications will suggest the maximum speeds that will be encountered on the course. Average speeds should be 40 km/hr (25 mph) to 48 km/hr (30 mph).

Straights: No longer than 60 m (200 feet) with hairpins at both ends (or) no longer than 45 m (150 feet) with wide turns on the ends.

Constant Turns: 23 m (75 feet) to 45 m (148 feet) diameter.

Hairpin Turns: Minimum of 9 m (29.5 feet) outside diameter (of the turn).

Slaloms: Cones in a straight line with 7.62 m (25 feet) to 12.19 m (40 feet) spacing.

Miscellaneous: Chicanes, multiple turns, decreasing radius turns, etc. The minimum track width will be 3.5 m (11.5 feet).

The length of each run will be approximately 0.805 km (1/2 mile) and the driver will complete a specified number of runs.

5.6.4 Autocross Penalties

The cars are judged on elapsed time plus penalties. The following penalties will be added to the elapsed time:



5.6.4.1 Cone Down or Out (DOO)

Two (2) seconds per cone, including any after the finish line.

5.6.4.2 Off Course

Driver must re-enter the track at or prior to the missed gate or a twenty (20) second penalty will be assessed. Penalties will not be assessed for accident avoidance or other reasons deemed sufficient by the track officials.

If a paved road edged by grass or dirt is being used as the track, e.g. a go kart track, four (4) wheels off the paved surface shall count as an "off course". Two (2) wheels off will not incur an immediate penalty; however, consistent driving of this type may be penalized at the discretion of the event officials.

5.6.4.3 Missed Slalom

Missing one or more gates of a given slalom will be counted as one "off-course" per occurrence. Each occurrence will incur a twenty (20) second penalty.

5.6.5 Stalled & Disabled Vehicles

If a car stalls and cannot restart without external assistance, the car will be deemed disabled. Cars deemed disabled will be cleared from the track by the track workers. At the direction of the track officials team members may be instructed to retrieve the vehicle. Vehicle recovery may only be done under the control of the track officials.

5.6.6 Corrected Elapsed Time

The elapsed time plus any penalties from that specific run will be used as the corrected elapsed time. Cars that are unable to complete the course with an average speed of 80% of the fastest car will not be awarded "performance" points. This means that any autocross time in excess of 125% of the fastest time will receive no "performance" points.

5.6.7 Best Run Scored

The time required to complete each run will be recorded and the team's best corrected elapsed time will be used to determine the score.

5.6.8 Autocross Scoring Formula

In the equation below, the first term on the right hand side represents "performance" points, while the second term, or "completion" points represents the minimum score for having successfully completed the event. The following equation is used to determine the autocross score:

$$\text{AUTOCROSS SCORE} = 142.5 \times \frac{\left(\frac{T_{\max}}{T_{\text{your}}}\right) - 1}{\left(\frac{T_{\max}}{T_{\min}}\right) - 1} + 7.5$$



Where:

T_{min} is the lowest corrected elapsed time recorded for any competitor in either heat

T_{max} is 125% of T_{min}

T_{your} is the lowest corrected elapsed time in either heat for the team being scored.

Negative “performance” points will not be given. However, 7.5 points will be given for a car that completes a run, even if T_{your} exceeds 125% of the fastest time (T_{min})



5.7 Endurance and Fuel Economy Event

400 Points

Notice: At Formula SAE competitions in North America the Endurance & Fuel Economy event will consist of a single heat.

Reminder – Driver Eligibility – The Endurance and Fuel Economy are separate events even though they are run simultaneously. Therefore anyone driving in a heat of Endurance and Fuel Economy uses two (2) driving eligibilities. See 5.3 “Driver Limitations”.

5.7.1 Right to Change Procedure

The following are general guidelines for conducting the endurance and fuel economy event. The organizers reserve the right to establish procedures specific to the conduct of the event at the site. All such procedures will be made known to the teams through newsletters or the specific FSAE competition website.

5.7.2 Endurance Objective—350 points

The Endurance Event is designed to evaluate the overall performance of the car and to test the car’s reliability.

5.7.3 Fuel Economy—50 points

The car’s fuel economy will be measured in conjunction with the endurance event. The fuel economy under racing conditions is important in most forms of racing and also shows how well the car has been tuned for the competition. This is a compromise event because the fuel economy score and endurance score will be calculated from the same heat. No refueling will be allowed during an endurance heat.

5.7.4 Endurance Course Specifications & Speeds

Course speeds can be estimated by the following course specifications. Average speed should be 48 km/hr (29.8 mph) to 57 km/hr (35.4 mph) with top speeds of approximately 105 km/hr (65.2 mph).

Straights: No longer than 77.0 m (252.6 feet) with hairpins at both ends (or) no longer than 61.0 m (200.1 feet) with wide turns on the ends. There will be passing zones at several locations.

Constant Turns: 30.0 m (98.4 feet) to 54.0 m (177.2 feet) diameter.

Hairpin Turns: Minimum of 9.0 m (29.5 feet) outside diameter (of the turn).

Slaloms: Cones in a straight line with 9.0 m (29.5 feet) to 15.0 m (49.2 feet) spacing.

Miscellaneous: Chicanes, multiple turns, decreasing radius turns, etc. The minimum track width will be 4.5 m (14.76 feet).



5.7.5 Endurance General Procedure

The event will be run as a single heat approximately 22 km (13.66 miles) long.

Teams are not allowed to work on their vehicles during the heat. A driver change must be made during a three (3) minute period at the mid point of the heat.

Wheel-to-wheel racing is prohibited. Passing another vehicle may only be done in an established passing zone or under control of a course marshal.

5.7.6 Endurance Fuel Fill

Before entering the event each vehicle's fuel tank must be filled to the fuel level line (see section 3.5.3.3, "Fuel Level Line") at the fueling station. During fueling, once filled to the scribe line, no shaking or tilting of the tank or fuel system (incl. entire vehicle) is allowed.

5.7.7 Endurance Vehicle Starting/ Restarting

The vehicle must be capable of starting / restarting without external assistance at all times once the vehicle has begun the heat. If a vehicle stalls out on the track, it will be allowed one (1) lap by the car that is following it (approximately one (1) minute) to restart. If a vehicle has a restart problem at the end of Driver Change, it will be allowed a further two (2) minutes to restart the engine. If restarts are not accomplished within the above times, the car will be deemed disabled and scored DNF for the heat.

5.7.8 Endurance Driver Change Procedure

Elapsed time will begin when Driver A enters the course and crosses the timing line. Driver A will drive for 11 km (6.83 miles), and pull into the driver change area. Three (3) minutes are allowed for the team to change drivers.

Driver A will exit the vehicle and any necessary adjustments will be made to the vehicle to fit Driver B (seat cushions, pedal position, etc.). Only three (3) team members, including the driver or drivers, will be allowed in the driver change area, and only the tools necessary to change drivers and/or tires will be carried into this area (no tool chests etc.). Extra people entering the driver change area will result in a 20 pt penalty to the final endurance score for each extra person entering the area.

Driver B will then be secured in the vehicle. The driver change area will be placed such that the timing system will see the driver change as an extra long lap. Unless this driver change takes longer than three minutes, this extra long lap will not count. If the driver change takes longer than three minutes, the extra time will be counted into the final time.

Driver B will drive for 11 km (6.83 miles) and elapsed time will stop when the car completes the total 22 km (13.66 miles) distance.

Driver B will proceed directly to the fueling station. The tank will be filled to refill mark and the amount will be recorded.

5.7.9 Entering the Track

Cars will be allowed to enter the track based upon the level of traffic on the course. The number of vehicles simultaneously on the course depends on the track length and design as well as the operating conditions. In dry conditions, there are typically 5 to 7 vehicles allowed per kilometer of track. This includes cars in the driver change area.

Because repairs are not allowed during the heat, and there will be no refueling during the heat, there will not be a restart queue of any kind.

5.7.10 Endurance Run Order

The run order for endurance will be based primarily on the finish order for the autocross event with the fastest team first followed by the second fastest etc. For teams without an autocross score, the finish order for the acceleration event may be substituted. For teams without a score in either autocross or acceleration, the finish order for skid pad may be substituted. Teams without a score in the event used to determine the run order may run at the end of the heat.

Based on the results of all dynamic events, and considering the operating conditions under which they were run, the endurance event captain may, at his sole discretion, move teams to different positions within the starting order.

Teams are required to keep track of the run order and have their cars fueled, in line and prepared to start when their turn to run arrives. Teams that are not ready-to-run when their turn arrives will be penalized two (2) minutes and permitted to run at the end of the heat (time permitting) or at the discretion of the event captain.

5.7.11 Breakdowns & Stalls

If a vehicle breaks down it will be removed from the course and will not be allowed to re-enter the course. If a vehicle stalls, or ingests a cone, etc., it will be allowed to restart and re-enter the course where it went off, but no work may be performed on the vehicle. If a car stalls and cannot be restarted without external assistance, the track workers will push the car clear of the track. At the discretion of event officials, two (2) team members may retrieve the car under direction of the track workers.

5.7.12 Endurance Minimum Speed Requirement

If a car is unable to maintain lap times within 133% of the fastest lap time for the course, then it must exit immediately. Disqualification for failure to maintain the minimum speed will be made at the discretion of the Chief Marshall/Director of Operations.

5.7.13 Exiting the Course

Vehicles must power down after leaving the course and be pushed into and out of the fueling area.



Fuel pumps will be turned on and fuel valves will be opened to insure complete refueling.

5.7.14 Endurance Lap Timing

Each lap of the endurance event will be individually timed either by electronic means, or by hand. The time for an individual heat will be determined by subtracting the extra long lap for the driver change from the total time and adding any penalty points.

5.7.15 Endurance Penalties

Penalties will not be assessed for accident avoidance or other reason deemed sufficient by the track official.

Additional driving rules will be found in other sections including 5.8 “Flags” and 5.12 “Driving Rules”.

The following penalties will be assessed:

5.7.15.1 Cones

Cone down or out (DOO) - two (2) seconds per cone. This includes cones before the start line and after the finish line.

5.7.15.2 Off Course (OC)

For an OC, the driver must re-enter the track at or prior to the missed gate or a twenty (20) second penalty will be assessed.

If a paved road edged by grass or dirt is being used as the track, e.g. a go kart track, four (4) wheels off the paved surface shall count as an "off course". Two (2) wheels off will not incur an immediate penalty.

However, consistent driving of this type may be penalized at the discretion of the event officials.

5.7.15.3 Missed Slalom

Missing one or more gates of a given slalom will incur a twenty (20) second penalty.

5.7.15.4 Penalties for Moving Violations

The following are penalties and assessed times or disqualifications for moving violations:

- a. Failure to obey a flag: 1 minute
- b. Over Driving (After a closed black flag): 1 Minute
- c. Vehicle to Vehicle contact: DISQUALIFIED



5.7.15.5 Out of Order

Running out of order – two (2) minute penalty.

5.7.15.6 Mechanical Problem

No additional penalty other than the time lost to ensure that the car is safe to continue.

5.7.15.7 Reckless or Aggressive Driving

Any reckless or aggressive driving behavior (such as forcing another car off the track, refusal to allow passing, or close driving that would cause the likelihood of car contact) will result in a black flag for that driver. When a driver receives a black flag signal, he must proceed to the penalty box to listen to a reprimand for his driving behavior. The amount of time spent in the penalty box will vary from one (1) to four (4) minutes depending upon the severity of the offense.

If it is impossible to impose a penalty by a stop under a black flag, e.g. not enough laps left, the event officials may add an appropriate time penalty to the team's elapsed time.

5.7.15.8 Inexperienced Driver

The Chief Marshall/Director of Operations may disqualify a driver if the driver is too slow, too aggressive, or driving in a manner that, in the sole opinion of the event officials, demonstrates an inability to properly control their car resulting in a DNF.

5.7.15.9 Poor Fuel Economy

Mileage exceeding 26 liters/100 km – four (4) minutes.

5.7.16 Endurance Scoring

The score for the Endurance Event is the sum of the Endurance Time Score and the Endurance Finish Score. The Endurance Time Score is based on the team's time for the event, including penalties, compared to the fastest team. A car will also receive an Endurance Finish Score of fifty (50) points if the team's time for the event, including penalties, is less than or equal to the maximum allotted time. The total Endurance Score is calculated using the formula below.



5.7.17 Endurance Scoring Formula

The times for the endurance event will be based upon the sum of the times of each driver in the heat plus penalties.

The following equation is used to determine the time scores for the event:

If **T_{your}** is < or = to **T_{max}** :

$$\text{ENDURANCE SCORE} = 300 \times \frac{(\text{T}_{\text{max}}/\text{T}_{\text{your}}) - 1}{(\text{T}_{\text{max}}/\text{T}_{\text{min}}) - 1} + 50$$

If **T_{your}** > **T_{max}**: ENDURANCE SCORE = 0 (ZERO)

T_{min} will be the lowest corrected time of the fastest team of the event.

T_{your} will be the combined corrected times of the drivers in your heat.

T_{max} will be based upon an average speed of 75% of the fastest team of the event; therefore, T_{max} will be 1.333 times T_{min}.

If, in the opinion of the officials, course conditions change significantly during the running of the event then they may, at their sole discretion, set T_{max} to a higher value.

5.7.18 Fuel Economy

The fuel economy score is based on the average liters per kilometer fuel economy obtained during the endurance heat.

5.7.19 E85 Correction Factor

The volume of E85 fuel will be divided by a 1.40 correction factor to determine the gasoline equivalent volume. This correction factor is equal to the ratio of energy (lower heating value) per unit volume of gasoline to E85.

5.7.20 Fuel Economy Scoring Formula

The following equation will be used to determine the fuel economy score:

$$\text{FUEL ECONOMY SCORE} = 50 \times \frac{(\text{V}_{\text{max}}/\text{V}_{\text{your}}) - 1}{(\text{V}_{\text{max}}/\text{V}_{\text{min}}) - 1}$$

Where:

V_{max} is equal to 5.72 liters (1.51 gallons) and will be adjusted to represent 26 liters/100 km (9.04 mpg) if the course is shortened or lengthened

V_{min} is the smallest volume of fuel used by any competitor

V_{your} is the volume of fuel used by the team being scored



Vehicles which consume more than 5.72 liters of fuel during the course of the endurance heat or whose corrected time exceeds 1.333 times the corrected time of the fastest team, will receive zero (0) points for fuel economy.

For shortened courses, V_{min} will be the low value per heat. Fuel economy scores can range from zero (0) to fifty (50) points.

5.7.21 Post Event Engine Check

The organizer reserves the right to impound any vehicle immediately after the event to check engine displacement (method to be determined by the organizer) and restrictor size.

5.7.22 Endurance and Fuel Economy Scoring with Two Heats

If the Endurance and Fuel Economy is run with two (2) heats, the following procedure will apply:

a) **T_{min}** will be the lowest corrected time of the fastest team of the event in either heat.

b) **V_{min}** will be the smallest volume of fuel used by any team in either heat; provided that team's Corrected Time from that heat does not exceed **T_{max}** .

Note: **T_{min}** and **V_{min}** do not have to be from the same heat.

c) The score for a team will be taken from the heat that gives the higher total Endurance & Fuel Economy Score for that team, i.e. **T_{your}** and **V_{your}** will be from the same heat.

5.8 Flags

The flag signals convey the commands described below, and shall be obeyed immediately and without question.

There are two kinds of flags for the competition: Command flags and Informational flags. Command flags are just that, flags that send a message to the competitor that the competitor must obey without question. Informational flags, on the other hand, require no action from the driver, but should be used as added information to help him or her to maximize performance. What follows is a brief description of the flags used at the competitions in North America and what each flag means.

Note: Not all of these flags are used at all competitions and some alternate designs are occasionally displayed. Any variations from this list will be explained at the drivers meetings.

5.8.1 Command Flags

BLACK FLAG - Pull into the penalty box for discussion with the Director of Operations or other official concerning an incident. A time penalty may be assessed for such incident.



BLACK FLAG With Orange Dot - Pull into the penalty box for a mechanical inspection of your car, something has been observed that needs closer inspection.

BLUE FLAG - Pull into the designated passing zone to be passed by a faster competitor. Obey the corner workers hand signals at the end of the passing zone to merge into competition.

CHECKER FLAG - Your session has been completed. Exit the course at the first opportunity.

GREEN FLAG - Your session has started, enter the course under direction of the starter. (NOTE: If you stall the vehicle, please restart and await another green flag as the opening in traffic may have closed.)

RED FLAG - Come to an immediate safe controlled stop on the course. Pull to the side of the course as much as possible to keep the course open. Follow corner worker directions.

YELLOW FLAG (Stationary) - Danger, **SLOW DOWN**, be prepared to take evasive action, something has happened beyond the flag station. **NO PASSING** unless directed by the corner workers.

YELLOW FLAG (Waved) - Great Danger, **SLOW DOWN**, evasive action is most likely required, **BE PREPARED TO STOP**, something has happened beyond the flag station, **NO PASSING** unless directed by the corner workers.

5.8.2 Informational Flags

RED AND YELLOW STRIPED FLAG - Something is on the racing surface that should not be there. Be prepared for evasive maneuvers to avoid the situation. (Corner workers may be able to point out what and where it is located, but do not expect it.)

WHITE FLAG - There is a slow moving vehicle on the course that is much slower than you are. Be prepared to approach it at a cautious rate.

5.9 Rules of Conduct

5.9.1 Competition Objective – A Reminder

The Formula SAE® event is a design engineering competition that requires performance demonstration of vehicles and is NOT a race. Engineering ethics will apply. It is recognized that hundreds of hours of labor have gone into fielding an entry into Formula SAE. It is also recognized that this event is an “engineering educational experience” but that it often times becomes confused with a high stakes race. In the heat of competition, emotions peak and disputes arise. Our officials are



trained volunteers and maximum human effort will be made to settle problems in an equitable, professional manner.

5.9.2 Unsportsmanlike Conduct

In the event of unsportsmanlike conduct, the team will receive a warning from an official. A second violation will result in expulsion of the team from the competition.

5.9.3 Official Instructions

Failure of a team member to follow an instruction or command directed specifically to that team or team member will result in a twenty five (25) point penalty.

Note: This penalty can be individually applied to all members of a team.

5.9.4 Arguments with Officials

Argument with, or disobedience to, any official may result in the team being eliminated from the competition. All members of the team may be immediately escorted from the grounds.

5.9.5 Alcohol and Illegal Material

Alcohol, illegal drugs, weapons or other illegal material are prohibited on the event site during the competition. This rule will be in effect during the entire competition. Any violation of this rule by a team member will cause the expulsion of the entire team. This applies to both team members and faculty advisors. Any use of drugs, or the use of alcohol by an underage individual, will be reported to the local authorities for prosecution.

5.9.6 Parties

Disruptive parties either on or off-site should be prevented by the Faculty Advisor.

5.9.7 Trash Clean-up

Cleanup of trash and debris is the responsibility of the teams. The team's work area should be kept uncluttered. At the end of the day, each team must clean all debris from their area and help with maintaining a clean paddock.

Teams are required to remove all of their material and trash when leaving the site at the end of the competition. Teams that abandon furniture, or that leave a paddock that requires special cleaning, will be billed for removal and/or cleanup costs.

5.10 General Rules

5.10.1 Dynamometer Usage

If a dynamometer is available, it may be used by any competing team. Vehicles to be dynamometer tested must have passed all parts of technical inspection.



Fuel, ignition and drivetrain tuning will be permitted while testing on the dynamometer.

5.10.2 Problem Resolution

Any problems that arise during the competition will be resolved through the Operations Center and the decision will be final.

5.10.3 Protests

(A) Required Review - Any team that intends to protest a rule, score, judge's decision or any other aspect of the competition, must present the issue to SAE staff for discussion, and possible resolution before the protest is filed.

(B) Cause for Protest - A team may protest any rule interpretation, score or official action (unless specifically excluded from protest) which they feel has caused some actual, non-trivial, harm to their team, or has had a substantive effect on their score. Teams may not protest rule interpretations or actions that have not caused them any substantive damage.

(C) Protest Period - Protests must be filed within one-hour (½) after the action being protested has occurred or the scores for the activity involving the protest subject are posted.

(D) Protest Format - Protests must be in writing and submitted to designated organizer or SAE staff.

(E) Protest Bond - The protesting team must post a twenty-five (25) point bond to be deducted from their score if the protest is denied.

(F) Decision - The decision of the officials regarding any protest is final.

5.10.4 Forfeit for Non-Appearance

It is the responsibility of teams to be in the right place at the right time. If a team is not present and ready to compete at the scheduled time they forfeit their attempt at that event. There are no make-ups for missed appearances.

5.10.5 Drivers Meetings – Attendance Required

All drivers for an event are required to attend the pre-event drivers meeting(s). The driver for an event will be disqualified if he/she does not attend the driver meeting for the event.

5.10.6 Personal Vehicles

Personal cars and trailers must be parked in designated areas only. Only FSAE competition vehicles will be allowed in the track areas.

5.10.7 Motorcycles, Bicycles, Rollerblades, etc.—Prohibited

The use of motorcycles, quads, bicycles, scooters, skateboards, rollerblades or similar person-carrying devices by team members and spectators in any part of the competition area, including the paddocks, is prohibited.

5.10.8 Self-propelled Pit Carts, Tool Boxes, etc. - Prohibited

The use of self-propelled pit carts, tool boxes, tire carriers or similar motorized devices in any part of the competition site, including the paddocks, is prohibited.

5.11 Pit Rules

5.11.1 Vehicle Movement

Vehicles may not move under their own power anywhere but on the practice or competition tracks. Off track vehicles must be pushed at a normal walking pace by means of a “Push Bar”, with all four (4) wheels on the ground, a team member sitting in the cockpit to steer and brake and with another team member walking beside the car. Cars with wings are required to have two team members walking on either side of the vehicle whenever the vehicle is being pushed. During performance events when the excitement is high, it is particularly important that the car be moved at a slow pace in the pits. The walking rule will be enforced and a point penalty of twenty five (25) points will be assessed for each violation.

5.11.2 Push Bar

Each car must have a removable device that attaches to the rear of the car that allows two (2) people, standing erect behind the vehicle, to push the car around the event site. This device must also be capable of decelerating, i.e. slowing and stopping the forward motion of the vehicle and pulling it rearwards. It must be presented with the car at Technical Inspection.

5.11.3 Smoking – Prohibited

Smoking is prohibited in all competition areas.

5.11.4 Fueling and Refueling

Officials must conduct all fueling and refueling.

5.11.5 Engine Running in the Paddock

Engines may be run in the paddock provided the car has passed technical inspection and the following conditions are satisfied:

- (A) The car is on an adequate stand, and
- (B) The drive wheels are at least 10.2 cm (4 in) off the ground, or the drive wheels have been removed.



5.12 Driving Rules

5.12.1 Driving Under Power

Cars may only be driven under power (a) when running in an event, (b) on the practice track and (c) during brake test or (d) during any powered vehicle movement specified and authorized by the organizers. For all other movements cars must be pushed at a normal walking pace using a push bar.

Violation of this rule will result in a two hundred (200) point penalty for the first violation and expulsion of the team for a second violation.

5.12.2 Driving Off-site

Driving off-site is absolutely prohibited. Teams found to have driven their vehicle at an off-site location during the period of the competition will be excluded from the competition.

5.12.3 Practice Track

A practice track for testing and tuning cars may be available at the discretion of the organizers. The practice area will be controlled and may only be used during the scheduled practice times. Practice or testing at any location other than the practice track is absolutely forbidden. Driving a vehicle outside of scheduled events or scheduled practice will result in a minimum two hundred (200) point penalty or disqualification at the organizer's discretion.

Cars using the practice track must have all parts of the technical inspection sticker.

5.12.4 Situational Awareness

Drivers must maintain a high state of situational awareness at all times and be ready to respond to the track conditions and incidents. Flag signals and hand signals from course marshals and officials must be immediately obeyed.

5.12.5 Endurance Event – Driving

During Endurance when multiple cars are running on the course it is paramount that the drivers strictly follow all of the rules and driving requirements. Aggressive driving, failing to obey signals, not yielding for passing, etc will result in a black flag and a discussion in the penalty box with course officials. The amount of time spent in the penalty box is at the discretion of the officials and is included in the run time. Penalty box time serves as a reprimand as well as informing the driver of what he/she did wrong. Drivers should be aware that contact between open wheel racers is especially dangerous because tires touching can throw one car into the air.

Endurance is a times event in which drivers compete only against the clock not against other cars. Aggressive driving is unnecessary.



5.12.6 Endurance Event – Passing

Passing during Endurance may only be done in the designated passing zones and under the control of the track officials. Passing zones have two parallel lanes – a slow lane for the cars that are being passed and a fast lane for the cars that are making a pass. On approaching a passing zone a slower leading car will be blue flagged and must shift into the slow lane and decelerate. The following faster car will continue in the fast lane and make the pass. The car that had been passed may reenter traffic only under the control of the passing zone exit flagman. Passing, i.e. slow, lanes may be either to the left or right of the fast lane depending on the design of the specific course.

These passing rules do not apply to cars that are passing disabled cars on the course or cars that have spun out and are not moving. When passing a disabled or off-track car it is critical to slow down, drive cautiously and be aware of all the vehicles and track workers in the area.

Under normal driving conditions when not being passed all cars use the fast lane.

5.12.7 Endurance Event – Driver’s Course Walk

The endurance course will be available for walk by drivers prior to the event. All endurance drivers are required to walk the course before the event starts.

5.13 Definitions

DOO - A cone is “Down or Out”—if the cone has been knocked over or the entire base of the cone lies outside the box marked around the cone in its undisturbed position.

DNF- Did Not Finish

Gate - The path between two cones through which the car must pass. Two cones, one on each side of the course define a gate: Two sequential cones in a slalom define a gate.

Entry Gate -The path marked by cones which establishes the required path the vehicle must take to enter the course.

Exit Gate - The path marked by cones which establishes the required path the vehicle must take to exit the course.

Staging Area - An area prior to the entry to an event for the purpose of gathering those cars that are about to start.

OC - A car is Off Course if it does not pass through a gate in the required direction.



6. NOTICE OF POSSIBLE RULE CHANGES FOR THE 2009 FORMULA SAE SERIES

This section is intended to provide teams with advance notice of possible changes to the Formula SAE Rules that are being considered by the Formula SAE Rules Committee. Only changes that may have a significant influence on a team's engineering design and manufacturing decisions are listed. This section is provided only for information and is not intended to be the final text of the rules under consideration.

The Air Intake System proposal that was included in Section 6 of both the 2006 and 2007 Rules will NOT be implemented. The Rules Committee has decided that it is in the best overall interest of the competition to leave rule on the location of the intake restrictor unchanged for the foreseeable future.

The Rules Committee is concerned that some teams are designing cockpits so small that the cars do not meet the intent of section 1.2 of the Rules and could also compromise certain other requirements.

For 2009, the Rules Committee are planning to:

- Tighten the requirements for the Impact Attenuator Data submission,
- Introduce three (3) requirements on the cockpit and cockpit opening.

The final dimensions and the exact configurations of the cockpit opening templates will be determined following surveys of cars at the 2007 competitions. As the dimensions are refined they will be published in the CDS Newsletters. And there will probably be a cut-out in the Template Y to miss the steering columns of low mounted steering racks.

3.3.6.4 Impact Attenuator Data Requirement

In addition to the current requirement that the average deceleration must not exceed 20 g, a new requirement will be added that the peak deceleration during the impact must not exceed 40 g.

Rule Number TBD - Cockpit

Cockpit Opening

In order to ensure that the opening giving access to the cockpit is of adequate size, a template shown in Drawing X will be inserted into the cockpit opening. It will be held horizontally and inserted vertically until it has passed below the top bar of the Side Impact Structure (or its equivalent for monocoque cars).

During this test, the steering wheel, steering column, seat and all padding may be removed.

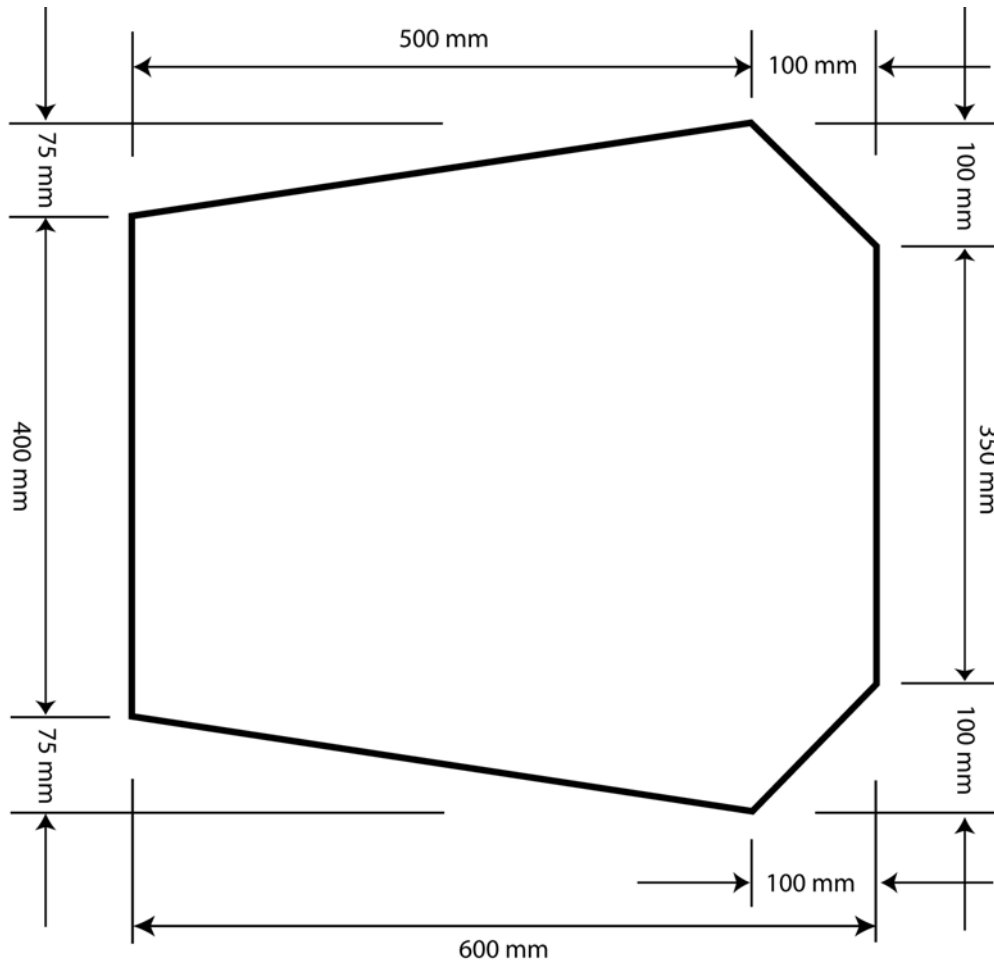

Drawing X

Internal Cross Section:

A. A free vertical cross section, which allows the template shown in Drawing Y to be passed vertically through the cockpit to a point 100 mm (4 inches) behind the face of the rearmost pedal when in the inoperative position, must be maintained over its entire length.

The only things that may encroach on this area are the steering wheel, steering column and any padding that is required by Rule 3.4.14. "Driver's Leg Protection".

B. The driver, seated normally with his seat belts fastened and with the steering wheel removed must be able to raise both legs together so that his knees are past the plane of the steering wheel in the rearward direction. This action must not be prevented by any part of the car.

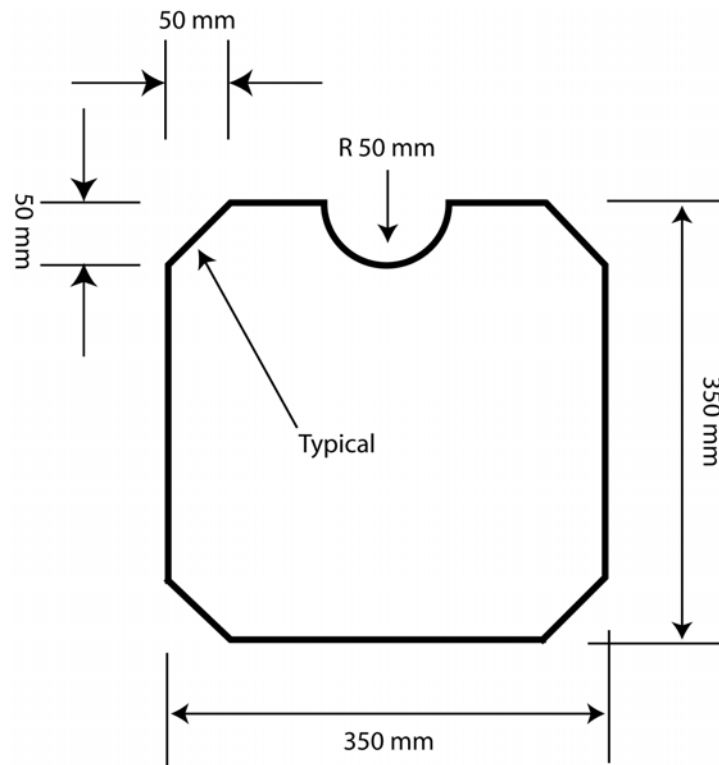

Drawing Y



7. QUESTIONS ABOUT THE FORMULA SAE RULES

7.1 Frequently Asked Questions

Before submitting a question, check the Frequently Asked Questions section of the Formula SAE website

7.2 Question Format

All rules questions must include (1) the full name and email address of the student submitting the question, (2) the name of the university – no abbreviations – and (3) the number of the applicable rule.

The following limits apply to questions submitted to the rules committee (1) No photograph, drawing or other attachment may exceed 100 KB in size (2) the total size of any question, with all attachments, must not exceed 1MB.

7.3 Response Time

Please allow a minimum of two (2) weeks for a response. The Rules Committee will respond as quickly as possible, however responses to questions presenting new issues, or of unusual complexity, may take more than two weeks. Please do not resend questions.

7.4 Submission Addresses:

Teams Entering Formula SAE competitions in North America
Send questions to: Kathleen McDonald, Formula SAE Consultant
Email: katklauz@aol.com

Teams entering only Formula SAE-Australasia:
Send questions to: Kristianna Pontikis, SAE-A
Email: formulasae@sae-a.com.au

Teams entering only Formula SAE Brasil:
Send questions to: SAE Brasil Organizers
Email: formula.saebrasil@saebrasil.org.br

Teams entering only Formula SAE Italy:
Send questions to: Luciano Pera, Formula SAE Italy, ATA Managing Director
Email: luciano.pera@crf.it

Teams entering only Formula Student:
Send questions to: IMechE Organizers
Email: formulastudent@imeche.org.uk



8. IMPORTANT FORMS AND DOCUMENTS

The following forms and documents are available to download at <http://www.sae.org/students/formula.htm> in Microsoft Word or Excel Format:

1. FSAE Structural Equivalency Form – (see Rule 3.3.2 and Appendix A-1)
2. FSAE Tech Sheet (see Rule 4.2.2)
3. Cost Report Supplement – (see Appendix A-2)
4. Design Specification Sheet (see Rules 4.5.2(b) & 4.5.3)



APPENDIX A-1

FSAE™ STRUCTURAL EQUIVALENCY FORM

If required, this form must be completed and submitted **no later than the date specified in the Action Deadlines**. The FSAE Technical Committee will review all submissions which deviate from the FSAE® rules. This form must also accompany the vehicle to Technical Inspection.

Structural Equivalency Forms (SEF) and supporting calculations must be submitted electronically in Adobe Acrobat Format (*.pdf). The submissions must be named as follows: schoolname_sef.pdf using the complete school name. **Please submit to the person indicated in the Action Deadlines for each event.**

*In the event that the FSAE Technical Committee requests additional information or calculations, teams have **one week from the date of the request** to submit the requested information.

University Name _____
 Team Contact _____
 Telephone Number & E-mail Address _____
 Faculty Advisor _____
 Telephone Number & E-mail Address _____

Rule Deviated: (check all that apply) and provide summary of change on each line, such as "Eight 5/16 inch Bolts" or "1.00 x 0.065 Square".

X	Rule No.	Rule Description	Design Description
	3.3.4.2	Main Roll Hoop	
	3.3.4.2.F	Main Roll Hoop Attachment to Monocoque	
	3.3.4.3	Front Roll Hoop Material	
	3.3.5.1	Main Roll Hoop Bracing	
	3.3.5.2	Front Roll Hoop Bracing	
	3.3.5.3	Monocoque Bracing Attachment	
	3.3.6.1	Front Bulkhead	
	3.3.6.1.D	Monocoque Front Bulkhead	
	3.3.6.2	Front Bulkhead Support	
	3.3.6.2.D	Monocoque Front Bulkhead Support	
	3.3.6.3	Impact Attenuator Attachment	
	3.3.8.1	Tube Frames Side Impact Structure	
	3.3.8.2	Composite Monocoque Side Impact Protection	
	3.3.8.3	Metal Monocoque Side Impact Protection	
	3.4.1.E	Monocoque Safety Harness Attachment	

ATTACH PROOF OF EQUIVALENCY

Please see "[Structural Equivalency Guide](#)" on SAE website for details of proof of equivalency calculations and supporting documentation.

TECHNICAL COMMITTEE DECISION/COMMENTS

Approved by _____ Date _____

NOTE: THIS FORM AND THE APPROVED COPY OF THE SUBMISSION MUST BE PRESENTED AT TECHNICAL INSPECTION AT EVERY FORMULA SAE EVENT ENTERED



**APPENDIX A-2
2008 FSAE COST EVENT ADDENDUM**

School: _____ **Car Number:** _____

(Please indicate decreases using bracketed numbers.)

	Section	Original Reported Total	New Reported Total	Difference	Cost Judge Initials
1					
2					
3					
4					
5					
6					
7					
8					

TOTAL VEHICLE \$ _____ \$ _____ \$ _____

Explanation of differences listed above:

1
2
3
4
5
6
7
8

Accepted by: _____	Entered by: _____
Date: _____	Date/Time: _____

Addendums will be accepted only at the time of registration on-site at the competition!

These forms will then be forwarded to the cost judges the morning of the cost event.



APPENDIX A- 3

The 2008 FSAE TM Cost Report must follow the organized list of systems and components outlined below. Any questions as to the correct location of the specific items **should be submitted to the rules committee by March 1, 2008 and clarification will be made.**

1) Brake System . . .

Brake Fluid	Brake Master Cylinder	Fasteners
Brake Lines	Brake Discs	Sub-totals of sub-components
Brake Pads	Balance Bar	Area total
Calipers	Proportioning valve	Graphics/Photographs
		Receipts/Back-up

2) Engine and Drivetrain . . .

Engine	Fuel Tank	Axles
Engine Mfr (Name)	Fuel Pump	Differential Mounts
Engine (cc)	Fuel Pressure Reg.	Sprocket/Pulleys
Displacement	Fuel Filter	Differential Bearings
Exhaust Manifold	Fuel Lines/Rails	Differential
Muffler	Fuel Vent/Check Valve	CV Joints/U Joints
Intake Manifold	Radiator	Shields
Restrictor	Coolant	Engine/Diff Oil
Air Filter	Overflow Bottles	Fasteners
Turbo/Super Charger	Coolant Lines	Sub-totals of sub-components
Carburetor / Throttle Body	Radiator Fans	Area Total
Engine Mounts	Hose Clamps	Graphics and/or Photographs
Oil Filter	Oil Cooler	Receipts/Back-Up
Spark Plugs	Chain / Belt	
Fuel Injectors	Ignition Coil / Wires	

3) Frame & Body . . .

Pedals	Body Material	Shifter Cable/Linkage
Shifter	Body Processing	Final Assembly
Throttle Controls	Body Attachments	Fasteners
Frame / Frame Tubes	Mounts Integral to Frame	Sub-totals of sub-components
Welding	Floor Pan	Area Total
Tubes Cuts/Bends	Clutch	Graphics and/or Photographs
Tube End Preps	Aerodynamic Wing (if used)	Receipts/Back-Up



4) Instruments, Wiring and Accessories . . .

Tachometer	Brake Light Bulb	Fasteners
ECM/Engine Electronics	Solenoids	Sub-totals of sub-components
Wire Harness/Connectors	Indicator Lights	Area Total
Oil Pressure Gage/Light	Battery	Graphics and/or Photographs
Dash Panel	Relays	Receipts/Back-Up
Kill Switch	Starter Button	
Fuses	Water Temperature Gage	

5) Miscellaneous, Finish and Assembly . . .

Seats	Fire Wall Area	Sub-totals of sub-components
On-Board Fire Suppression Sys.	Mirrors	Total
Driver's Harness	Shields	Graphics/Photographs
Paint - Frame	Headrest / Restraints	Receipts/Back-Up
Paint - Body		

6) Steering System . . .

Steering Rack	Steering Wheel Quick Release	Area Total
Steering Shaft	Fasteners	Graphics/Photographs
Steering Wheel	Sub-totals of sub-components	Receipts/Back-Up
Tie Rods		

7) Suspension and Shocks . . .

Shocks	Front A/Arms or Equivalent	Fasteners
Springs	Rear A/Arms or Equivalent	Sub-totals of sub-components
Suspension Mechanism	Front Uprights	Area Total
Pushrods/Pullrods	Rear Uprights	Graphics and/or Photographs
Rod Ends	Bell Cranks	Receipts/Back-Up

8) Wheels, Wheel Bearings and Tires . . .

Wheels	Wheel Bearings	Fasteners
Lug Nuts	Front Hubs	Sub-totals of sub-components
Tires	Rear Hubs	Area Total
Valve Stems	Wheel Studs	Graphics and/or Photographs
Wheel Weights		Receipts/Back-Up



Cost Report Evaluation (Overall Presentation)

The Cost Report will be evaluated for Content, Accuracy, and Organization.

Printed Cost Reports should contain:

- 1) Cover / Binder - including car number and school name (required)
- 2) Cover Sheet
- 3) Table of Contents
- 4) Cost Summary Page
- 5) Tabs for each section
- 6) Process descriptions of up to ten pages for each section (required)
- 7) Bill of Material (required)
- 8) Assembly Labor Total in each BOM section (required)
- 9) Back up Data
- 10) Graphics/Photos
- 11) Electronic copy of the BOM in Excel Office 97 (required) on a single 3.5" floppy disk (preferred) or a CD-ROM (accepted)

Note:

After each section or area, please include the corresponding pictures, sketches, diagrams, blueprints (if possible), back-up and receipts necessary for that area. The cost of fasteners and brackets are to be included in their respective sub-assemblies. The labor and operations to process the component or sub-assemblies must be included in each sub-assembly as if each assembly were purchased from a separate supplier and the car was assembled as a finished product.



APPENDIX A- 4 Manufacturing and Cost Analysis Example

Area or Commodity	Part Name	Description / Model # or Part #	Purchased or Manufactured (P or M)	Quantity	What you paid	Retail Cost Each	Unit of Measure	Supplier's Name and Phone Number	Total Retail Cost
Commodity Name from Appendix A3	Items required in each section are listed in Appendix A3								= Quantity x Retail Cost Each
1 Brake System	"Widget A"	#304A	P	3	\$12.00	\$15.00	Each	Amalgamated Auto (248) 555-1212	\$ 45.00
2 Brake System	"Widget B"	Altered Widget	M	3	--	\$20.83	Each	Amalgamated Auto (248) 555-1212	\$62.50
3 Brake System	"Widget C"	Custom	M	1	\$15.53	\$ 15.53	Each	Whatsamatta U.	\$ 15.53
Brake Sub-total									\$XX.XX

Sub-Total for each Area or commodity									
4 Assembly Cost		M	X			\$Y	unit		\$ X*Y
Grand Total of Vehicle									\$\$\$



APPENDIX A- 5

SCHOOL _____ CAR NUMBER _____

PRESENTATION JUDGING

Score the following categories on the basis of 0-10 points each according to the following scale (any number or fraction along this scale may be used).

- 0.0 = inadequate or no attempt
- 2.5 = attempted but below expectation
- 5 = average or expected
- 7.5 = above average but still lacking
- 10 = excellent, perfectly meets intent

_____ **CONTENT:** Were the concepts presented appropriate and adequate to explain how the car meets the intent of the customer? Were enough technical details presented without being boring?

_____ **ORGANIZATION:** Were the concepts presented in a logical order progressing from basic concept and showing how the engineering accomplished the concept? Was it clear to the audience what was to be presented and what was coming next? Were distinct introduction and overviews as well as summary and conclusions given?

_____ **VISUAL AIDS:** Were visual aids used or clear visual references made to the car? Were the illustrations visible for all of the audience?

_____ **DELIVERY:** Did the presenter speak in a clear voice? Did the presenter show enthusiasm and promote confidence in the technical aspects? Did he maintain eye contact?

_____ **QUESTIONS:** Did the answer illustrate that the team fully understood the question? Is there doubt that the team understood the answer? Did the team promote complete confidence in their response to the questions?

_____ **TOTAL = PRESENTATION POINTS (50 points maximum)**

COMMENTS: _____



APPENDIX A- 6

SCHOOL _____ CAR NUMBER _____

DESIGN JUDGING

- _____ **AESTHETICS (0-5)** - Does the vehicle look attractive? Does it have a high performance appearance?
- _____ **MECHANICAL DESIGN (0-20)** - Do components appear to have been sized properly for the load? Does form follow function? Do brackets serve more than one purpose?
- _____ **CHASSIS DESIGN (0-30)** - Does the suspension design consider kinematics, roll center placement or load transfer? How was vehicle handling designed for and developed? How was brake system designed? Was weight distribution and C.G. height optimized?
- _____ **MANUFACTURABILITY (0-10)** - Can 1000 units per year be economically produced? Was manufacturing and ease of assembly a major consideration?
- _____ **SERVICEABILITY (0-15)** - Is the engine easy to service or remove? Is the suspension easy to adjust?
- _____ **INNOVATIVENESS (0-15)** - Are any of the components or systems unique? Do the innovations add to the product's functions?
- _____ **ERGONOMICS/INTERIORS/SAFETY (0-20)** - Is the vehicle designed to accommodate & function with a wide variety of body sizes? Are controls and instruments easy to use? Does the design consider occupant safety beyond the requirements?
- _____ **POWERTRAIN (0-30)** - Does the engine have significant modifications with respect to fuel injection, turbocharging, intake or exhaust? Was the drivetrain well done? Were throttle, drive controls designed well?
- _____ **BUILD QUALITY (0-5)** - Fit and finish, quality of materials, detail work, quality appearance.
- _____ **MISCELLANEOUS (0 to -50)** - If (a) this entry is a second year car and did not undergo significant improvements (not applicable in North America) or (b) if the team does not exhibit a good understanding of the car, then a penalty may be applied.
- _____ **TOTAL = DESIGN POINTS (150 points maximum)**

COMMENTS: _____



APPENDIX A- 7

Formula SAE Series Competition and Document Submission Information

Information on the dates, locations and document submission deadlines and addresses for the competitions of the Formula SAE Series are not included in the Rules. This information will be posted separately on the Formula SAE section of the SAE Collegiate Design Series website and the other competition websites as it becomes available. Date, location and document submission information is typically released 6 to 8 months prior to the competition.

The following information is tentative:

2008 Formula SAE at VIR will be held at Virginia International Raceway in April.

2008 Formula SAE will be held at Michigan International Speedway in May.

2008 Formula SAE West will be held at California Speedway in June.

SAE Australasia anticipates that 2008 Formula SAE Australasia will be held in Werribee, Victoria in early December.

SAE Brazil anticipates that 2008 Formula SAE Brazil will be held in October at site to be selected.

ATA anticipates that 2008 Formula SAE Italy will be held in September at a site to be selected.

IMechE anticipates that 2008 Formula Student will be held in July at Silverstone.



APPENDIX A- 8

2008 Formula SAE at VIR Wednesday, April 23 – Saturday, April 26, 2008 Virginia International Raceway Alton, Virginia

Co-located Event - FSAE at VIR will be held at Virginia International Raceway in conjunction with the VIR 400 which is part of the Grand American Rolex Sports Car Series. VIR 400's main event will be held on Sunday, April 27th and participating FSAE teams will have the opportunity to stay and watch the race.

This will be the first time an FSAE competition has been co-located with a major motor sports race and we've made some minor changes to our registration and operating procedures that are specific to this event. Please keep in mind that there will be two competitions running at the same facility at the same time and that some of the areas of VIR assigned to FSAE interlock with those designated for the VIR 400. You should expect a lot of interest in your team and car.

Registration - Registration for 2008 FSAE at VIR will open Monday, October 1, 2007 at 10:00 am EDT. The registration fee for the 2008 FSAE competitions in North America is \$1,000.00 each.

Dual Registration – For 2008 you will be permitted to register for both FSAE at VIR and for one other competition at the same time. Specifically, registering your team for both FSAE at VIR and either FSAE or FSAE West will be permitted during the first month of registration.

Registration Limit – Registration for 2008 FSAE at VIR is capped at 50 teams.

Team Member Registration Limit – Your registration fee will also cover admission of ten (10) team members or faculty advisors to VIR for both Formula SAE and the VIR 400 event.

Any additional team members or faculty advisors after the first ten (10) will be required to pay the standard VIR event entry fee of approximately \$45 each.

Paddocks – The paddocks will be on grass.

Electrical Power – Power will not be provided to the individual paddocks, so if you intend to run lights or power tools you will need to bring your own generator.

Course – Autocross and Endurance/Fuel Economy will be run on the Patriot Course.

Camping – Camping is available onsite at VIR.

VIR Website – You can find details on VIR, the Patriot Course and the area around the Raceway at www.virclub.com/vir/